

Module – I

ESTIMATE AND ESTIMATION

WHAT IS AN ESTIMATE

- Before taking up any work for its execution, the owner or builder should have a thorough knowledge about the volume of work that can be completed within the limits of his funds or the probable cost that may be required to complete the proposed work.
- It is therefore necessary to prepare the probable cost or estimate for the proposed work from its plan and specification.
- Otherwise, it may so happen that the work has to be stopped before its completion due to the shortage of funds or of materials.
- Besides the above , an estimate for any public construction work is required to be prepared and submitted beforehand so that sanction of necessary funds may be obtained from the authority concerned .
- Thus an estimate for any construction work may be defined as the process of calculating the quantities and costs of the various items required in connection with the work .
- It is prepared by calculating the quantities, from the dimensions on the drawings for the various items required to complete the project and multiplied by unit cost of the item concerned.
- To prepare an estimate , drawing consisting of the plan , the elevation and the section through important points, along with a detailed specification giving specific description of all workmanship , properties and proportion of materials , are required.

PURPOSE OF ESTIMATING:-

- To ascertain the necessary amount of money required by the owner to complete the proposed work . For public construction work, estimates are required in order to obtain administrative approval , allotment of funds and technical sanction.
- To ascertain quantities of materials required in order to programme their timely procurement. To procure controlled materials, if any, like cement , steel, etc. quantities of such materials are worked out from the estimate of the work and attached with the application for verification.

- To calculate the number of different categories of workers that is to be employed to complete the work within the scheduled time of completion.
- To assess the requirements of tool , plants and equipment required to complete the work according to the programmed.
- To fix up the completion period from the volume of works involved in the estimate.
- To draw up a construction schedule and programmed and also to arrange the funds required according to the programming.
- To justify the investment from benefit cost ratio.(for ideal investment ,this ratio should be more than one)
- To invite tenders and prepare bills for payment.
- An estimate for an existing property is required for valuation

TYPES OF ESTIMATE

- ROUGH COST ESTIMATE
- PLINTH AREAESTIMATE
- CUBICAL CONTENT ESTIMATE
- A QUANTITY ESTMATE
- APPROXIMATE QUANTITY METHOD
- DETAILED OR ITEM RATE ESTIMATE
- REVISED ESTIMATE
- SUPPLEMENTARY ESTIMATE
- REPAIR AND MAINTENANCEESTIMATE
- A COMPLETE ESTIMATE

ROUGH COST ESTIMATE

IT is prepared to decide the financial policy matter.it is prepared on basis of practical knowledge and cost of similar works. The competent sanctioning authority accords "Administrative approval

- These estimates are also referred to as rough estimate and are useful for go/no kind decision making which essentially refers to whether the project should or should not be pursued
- Some of the methods that can be useful for such estimates are investment per annual capacity turnover and capital ratio .

PLINTH AREA ESTIMATE

- It is prepared on the basis of plinth area of the building multiplied by plinth area rate prevalent in the region.
- Plinth area rates are fixed from the cost of similar buildings constructed in the locality having similar finishing's and amenities
- The cost of construction is determined by multiplying plinth area with plinth area rate. The area is obtained by multiplying length and breadth (outer dimensions of building). In fixing the plinth area rate, careful observation and necessary enquiries are made in respect of quality and quantity aspect of materials and labor, type of foundation, height of building, roof, wood work, fixtures, number of stores etc.

CUBICAL CONTENT ESTIMATE

- This estimate is worked out on the basis of the cubical contents of proposed building to be constructed and then applying to it the rate per cubic meter.
- This is more accurate than plinth area estimate.
- The cubic content rates are deduced from the cost of similar buildings constructed in the same locality
- This method is generally used for multi-storied buildings. It is more accurate than the other two methods viz., plinth area method and unit base method.
- The cost of a structure is calculated approximately as the total cubical contents (Volume of buildings) multiplied by Local Cubic Rate.
- The volume of building is obtained by Length x breadth x depth or height. The length and breadth are measured out to out of walls excluding the plinth offset

A QUANTITY ESTIMATE OR QUANTITY SURVEY

- This is complete estimate or list of quantities for all items of work required to complete the concerned project.
- The quantity of each individual items of work is worked out from respective dimensions on the drawing of the structure to find the cost of an item in quantity is multiplied by the rate per unit from that item.

- The purpose of the bill quantity i.e. to provide a complete list of quantities necessary for the competition of any engineering project and when price given to the estimated cost of the project.

APPROXIMATE QUANTITIES

- Regarded as the most reliable and accurate method of estimating, provided that there is sufficient information to work on. Depending on the experience of the surveyor, measurement can be carried out fairly quickly using composite rates to save time.
- The rules of measurement are simple, although it must be said; they are not standardized and tend to vary slightly from one surveyor to another. One approach involves grouping together items corresponding to a sequence of operations and relating them to a common unit of measurement; unlike the measurement for a bill of quantities,
 - where items are measured separately
 - Composite rates are then built up from the data available in the office for that sequence of operations
 - All measurements are taken as gross over all but the very large openings
 - Initially, the composite rates require time to build up, but once calculated they may be used on a variety of estimating needs
 - Reasonably priced software packages are now available. An example for a composite is shown below for substructure:
 - This is an approximate estimate to find out an approximate cost in the short time and thus enable the authority concerned to consider the financial aspect of the scheme for according sanctioned the same.
 - Such an estimate is framed after knowing the rates of similar works and form practical knowledge in various ways for various types of work such as
 - Plinth area or square meter method.
 - Cubic rate or cubic meter method.
 - Serve unit or unit rate method.
 - Bay method.

- Approximate quantities with bill method.
- Cost comparison method
- Cost from materials and labor.

DETAILED OR ITEM RATE ESTIMATE

- This estimate is an accurate and is based on the plan and sanctions of the building.
- The quantity of items under each sub head of work are calculated from the dimensions taken from drawing and then total cost is worked out in a form called abstract of cost
- This include the detailed particulars for the quantities ,rate and cost of all the items involved for satisfactory completion of a project
- Quantities of all items of work are calculated from their respective dimension on the drawing on a measurement sheet .multiplying these quantities by their respective rate in separate sheet, the cost of all items of work are worked out individually and then summarized
- A detail estimate is accompanied by
 - Report
 - Specification
 - Detailed drawing showing plane Design data and calculation
 - Basis of rates adopted in the estimate

REVISED ESTIMATE

- IT Is also a detailed estimate and is prepared a fresh when the original sanctioned detailed estimate exceeds by 10% or more ,either due to rates being found insufficient or due to some other reasons
- It is always possible that in spite of all precaution in the planning stages it becomes clearly during execution the actual cost of a project will exceed the original estimate ,now generally a certain cushion of the cost is available ,if the exceedance is higher
- It is prepared on the basis on estimate on which sanction was obtained showing the existing sanction and the progress made up to date
- The revised estimate should be accompanied by comparative statement showing the original and revised rate and quantity

SUPPLEMENTARY ESTIMATE

- This is a fresh detailed estimate of the additional work in addition to the original one and is prepared when additional work is required to supplement the original work
- There is always a like hood that while executing a certain project it may be considered worthwhile to carry out additional work ,which was not foreseen in initial stages and therefore not actual for the preliminary estimate

- Execution of such work required drawing up and approval of supplementary estimate and the exercise is essential similar to that of drawing up the estimate for the main work it is naturally expected that the cost of additional work will be much smaller than the main work
- In case where a substantial section of a project is abandoned or where material deviation from the original proposals are expected to result in substantial savings the estimate is revised by the department and intimated to engineer in charge for execution of work
- But in case where the saving is due to a material deviation of structural nature from the design originally approved supplement estimate is prepared for a revised technical sanction
- The method of preparation of supplementary estimate is the same as that of detail estimate and it should be accompanied by full report of the circumstances which render it necessary.
- The abstract must show the amount of original estimate and the total of sanctioned required including the supplementary amount.

REPAIR AND MAINTENANCE ESTIMATE

- In order to keep the structure roads etc in proper condition annual repairs and carried out annually for which an estimate is prepared. The estimated amount should not be more than 1.5% of the capital cost of work
- There are more than 10,000 maintenance, repair and preventive maintenance tasks for all types of facilities. With advances in telecommunications, computers and other workplace technologies, the list is growing rapidly. In a downsized, fiscally conservative environment, facilities are seen as vital capital assets that affect employee productivity. The demands for technical expertise and cost-effective plant operations have increased dramatically.
- After completion of a work it necessary to maintain the same for the proper function and for the same an estimate is prepared for items which required renewal, placement, repairs, etc in form of detailed estimate
- For building, such items of work like white washing, color and painting of doors and windows etc. quantities are based on the previous measurement recorded in measurement book as standard measurement books .for pretty works such as replacement of glass panes, repairs of floors patch repairs to cement plaster walls and changing roof tiles or similar natural works
- The total estimate coat of maintenance of structural is generally kept within the prescribe limits on percentage basis of the cost of the construction of the structure and its imp.
- The total estimated cost of maintenance of structure is generally kept within the prescribed limits on percentage basis (Variable according to the age and importance of the structure) of the cost of the construction of the

structure and its importance.

COMPLETE ESTIMATE

- This is an estimated cost of all items which are related to the work in addition to main contractor to the detailed estimate
- One may think that an estimate of a structure includes only the cost of land and the cost items to be included.

Most of people think that the estimate of a structure includes cost of land, cost of materials and labour, But many other direct and indirect costs included and is shown below.

The Complete Estimate

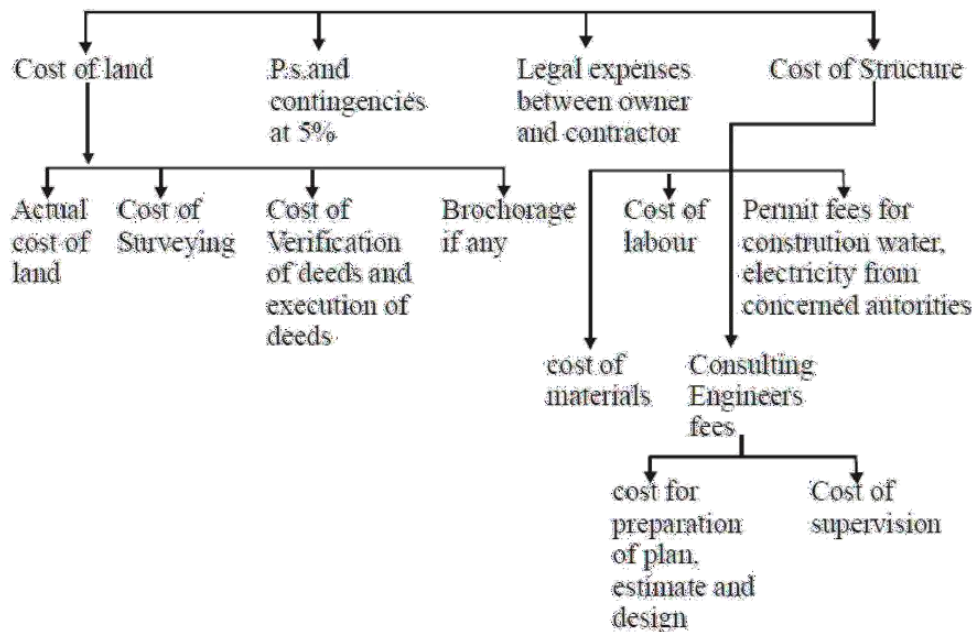

INTERNATIONAL SYSTEM OF UNIT

The Traditional Metric System (MKSA system)- Metre, Kilogram, Second, Ampere System) does not include the unit of Thermodynamic temperature and the unit of Luminous intensity. The International Conference adopted the International System of Units (SI) which includes six basic units. The six basic units with their symbols are- Metre(M) for length, Kilogram(Kg) for mass, Second(S) for time, Ampere(A) for electric current, Degree Kelvin(K) for thermodynamic temperature and Candela(Cd) for luminous intensity. The SI unit covers the co-herent units of the system (the basic units, supplementary units and the co-herent derived units and decimal multiples and sub-multiples of the units formed by the uses of the prefixes. The co-herent units only are designated SI units.

A system of unit is co-herent if the product or quotients of any two units quantities in the system is the unit of the resultant quantity – for example, in ay co-herent system, unit of area results when the unit length is multiplied by unit length; unit velocity when the unit length is divided by unit time; and unit force when the unit mass is multiplied by unit acceleration etc.. Whatever be the system of units, the magnitudes of some physical quantities must be arbitrarily selected and declared to have unit value. The magnitudes form a set of standard and are called “basic unit”. All other units are derived units related to the basic units by definition.

Basic SI Units

- Units of Length- Metre(M)- The metre is the length equal to 1650673.73 wave lengths in vacuum of the radiation corresponding to the transition between the levels $2p_{10}$ and $5d_5$ of the Krypton 86 atom.
- Unit of Mass-Kilogram (Kg)- The kilogram is the unit of mass and is equal to the mass of the international prototype of the Kilogram.
- Unit of Time- Second(s)- The second is the duration of 9192 631 770 periods of the radiation corresponding to the transition between the hyperfine levels of the ground state of the Cesium 133 atom.
- Unit of Electric Current- Ampere(A)- The ampere is that constant current which, if maintained in two straight parallel conductors of indefinite length, of negligible circular cross-section and placed one metre apart in vacuum, would produce between these conductors of force equal to 2×10^{-7} Newton per unit length.
- Unit of Thermodynamic Temperature- Kelvin (K)-The Kelvin unit of the thermodynamic temperature of the triple point of water. Kelvin may be used for expressing a temperature interval. The degree Celsius ($^{\circ}\text{C}$) is a unit of the International practical Temperature scale on which the thermodynamic temperature of zero point is 273.16K. The degree Celsius is equal to Kelvin ($1^{\circ}\text{C}-1\text{K}$). The degree Celsius may also be used for expressing a temperature interval.

- Unit of Luminous Intensity- Candela (cd)- The candela is the luminous intensity, in the perpendicular direction of a surface of $1/600,000$ square metre of a black body at the temperature of freezing platinum, under a pressure of 101.325 Newton's per square metre.

Supplementary Units- In the International System of units, the quantities, plane angle and solid angle are treated as independent quantities with SI units *radian* (rad.) and *steradian* (sr.) respectively.

One radian is the angle between two radii of a circle which cuts off on the circumference an equal in length to the radius.

One steradian is the solid angle which having its vertex in the centre of a sphere cuts off an area of the surface of the sphere equal to that of square with sides of length equal to the radius of the sphere.

Derived Units- The expressions for the derived SI units are stated in terms of the basic units as the SI units for velocity is metre per second (m/s). For some of the derived units, special names have been adopted together with special letters symbols, as the SI unit for force is *Newton* (N), for *energy* is (J), for power is *watt*(W), etc.. Some derived SI Units are also expressed in terms of the units from which they are derived as the SI unit for area is *square metre* (m^2) for volume is *cubic metre*(m^3) for density is *kilogram per cubic metre* (kg/m^3) etc..

METHOD OF ESTIMATING

The quantities like earth work, foundation concrete, brickwork in plinth and super structure etc., can be worked out by any of the following two methods:

- a) **Long wall - short wall method**
- b) **Centre line method.**
- c) **Partly centre line and short wall method.**

LONG WALL-SHORT WALL METHOD:

In this method, the wall along the length of room is considered to be long wall while the wall perpendicular to long wall is said to be short wall. To get the Measurement of Materials and Works length of long wall or short wall, calculate first the centre line lengths of individual walls. Then the length of long wall, (out to out) may be calculated after adding half breadth at each end to its centre line length. Thus the length of short wall measured into in and may be found by deducting half breadth from its centre line length at each end. The length of long wall usually decreases from earth work to brick work in super structure while the short wall increases. These lengths are multiplied by breadth and depth to get quantities

B) CENTRE LINE METHOD:

This method is suitable for walls of similar cross sections. Here the total centre line length is multiplied by breadth and depth of respective item to get the total quantity at a time. When cross walls or partitions or verandah walls join with main wall, the centre line length gets reduced by half of breadth for each junction. Such junction or joints are studied carefully while calculating total centre line length. The estimates prepared by this method are most accurate and quick.

C) PARTLY CENTRE LINE AND PARTLY CROSS WALL METHOD:

This method is adopted when external (i.e., around the building) wall is of one thickness and the internal walls having different thicknesses. In such cases, centre line method is applied to external walls and long wall-short wall method is used to internal walls. This method suits for different thicknesses walls and different level of foundations. Because of this reason, all Engineering departments are practicing this method.

HOW TO PREPARE A DETAILED ESTIMATE

- **Detailed Estimate:** The unit-quantity method is followed to prepare a

detailed estimate. In this method the rates per unit work of one item including profit are considered first and the total cost for the item is found, by multiplying the cost per unit of rate by the number.

- The procedure for the preparation of a detailed estimate is divided into 2 parts:

DETAILS OF MEASUREMENT AND CALCULATION OF QUANTITIES .

MEASUREMENT FORM: -

Item no	Description or particulars	-No	length	Breadth	- Height or Depth	Content or quantity	Remark

Abstract of estimate form

Sl .no	Description or particulars	Quatity	Unit	Rate Rs. P.	Unit of rate	Amount Rs. P.

Functions of an abstract of estimate

The main functions of an abstract of estimate are:

- The total estimated cost and the different items of works required to complete project can be known.
- Basis on which % rate tenders are called after excluding the amount for contingency and work-charged establishment.
- A part of tender document and a contractor can arrive at his own rates from the schedule of work described in the description column.
- This is the basis on which bills are prepared for payment. Comparative costs of different items of works can be known.

Data required for preparing detailed estimate

- DRAWING
- SPECIFICATIONS(both general and detailed)
- RATES
- UPDATED MODE OF MEASUREMENT
- STANDING CIRCULARS

FACTORS CONSIDERED DURING DETAILED ESTIMATION

- (a) Quantity of materials
- (b) Availability of materials

- (c) Transportation of materials
- (d) Location of site
- (e) Local labour charges

Principle of Units for Various Items Of Works-

The units of different works depend on their nature, size and shape. In general, the units of different items of work are based on the following principle:-

- i) Mass, voluminous and thick works shall be taken in square unit or volume. The measurement of length and breadth or height shall be taken to compute the volume or cubic contents.
- ii) Shallow, thin and surface works shall be taken in square units or in area. The measurement of length and breadth or height shall be taken to compute the area.
- iii) Long and thin work shall be taken in linear or running unit, and linear measurement shall be taken.
- iv) Piece work, job work, etc., shall be taken in number.

The units of payments and measurement of various items of work in metric system are same except for earthwork. Earthwork is measurement in cu m but payment is made per 100 cu m(per % cu m).

THE UNITS OF MEASUREMENTS AND PAYMENTS FOR VARIOUS ITEMS OF WORK AND MATERIALS

SL. NO.	Particulars of Items	Units of measurements in MKS	Units payment in MKS	Units of payment in FPS
1.	Earthwork- Earthwork in excavation in ordinary soil, earthwork in mixed soil with kankar bajri, etc. earthwork in hard soil.	cu m	Per % cu m	% cu ft
2.	Rock excavation	cu m	Per % cu m	% cu ft
3.	Earth filling in excavation in foundation.	cu m	Per % cu m	% cu ft
4.	Earth filling in foundation trenches	cu m	Per % cu m	% cu ft
5.	Earth filling in plinth	cu m	Per % cu m	% cu ft
6.	Earthwork in banking, cutting, in road and irrigation channel.	cu m	Per % cu m	% cu ft
7.	Surface dressing and levelling, cleaning, etc	sq m	Per sq m	% sq ft
8.	Cutting of trees (Girth specified)	no.	Per no.	Per no.
9.	Pudding, puddle clay core	cu m	Per % cu m	% cu ft
10.	Sand filling	cu m	Per cu m	% cu ft
11.	Quarrying of stone or boulder	cu m	Per cu m	% cu ft
12.	Blasting of rock (blasted stone stacked and then measured)	cu m	Per cu m	% cu ft
1.	Concrete- Lime concrete (L.C) in foundation	cu m	Per cu m	% cu ft
2.	Lime concrete (L.C) in roof terracing, thickness specified	sq m	per sq m	% sq ft
3.	Cement concrete (C.C)	cu m	per cu m	per cu ft
4.	Reinforced cement concrete (R.C.C.)	cu m	per cu m	per cu ft
5.	C.C. or R.C.C. Chujja, sun shade	cu m	per cu m	per cu ft
6.	Precast C.C. or R.C.C.	cu m	per cu m	per cu ft
7.	Jali work or jaffri work or C.C. tracery panels (Thickness specified)	sq m	per sq m	per sq ft
8.	Cement concrete bed	cu m	per cu m	per cu ft

9.	D.P.C.- Damp proof course-Cement concrete,rich cemen mortar.asphalt,etc.(Thicknes s specified)	sq m	per sq m	% sq ft
1.	Brickwork- Brickworkin foundation and plinth in super structure,in arches,etc., in cement,lime or mud mortar	cu m	per cu m	% cu ft
2.	Sun dried brickwork	cu m	per cu m	% cu ft
3.	Honey-comb brickwork,thickness specified	sq m	per sq m	%sq ft
4.	Brickwork in jack arches,if measured separatly	cu m	per cu m	% cu ft
5.	Jack arch roofing including top finishing	sq m	per sq m	% sq ft
6.	Brickwork in well steining	cu m	per cu m	% cu ft
7.	Half-brickwork with or without reinforcement	sq m	per sq m	% sq ft
8.	Thin partition wall	sq m	per sq m	% sq ft
9.	Reinforced brickwork (R.B.WORK)	cu m	per cu m	% cu ft
10.	String course,drip course,weather course,coping etc.(Projection specified)	meter	per m	per r ft
11.	Cornice(Projection and type specified)	meter	per m	per r ft
12.	Brickwork in Fire place,Chullah,Chimney	cu m	per cu m	% cu ft
13.	Pargetting Chimney,fire place flue	meter	per m	per r ft
14.	Brick edging (by road side)	meter	per m	per r ft
1.	STONE WORK- Stone masonry,Random Rubble masonry,Coursed Rubble masonry,Ashlar masonry in walls, in arches,etc.	cu m	per cu m	% cu ft
2.	Cut stone work in lintel beam,etc.	cu m	per cu m	per cu ft
3.	Stone slab in roof,shelve,etc.,stone chujjas,stone sun shed etc.	sq m	per sq m	% sq ft
4.	Stone work in wall facing or lining(Thickness specified)	sq m	per sq m	per sq ft
	WOOD WORK-			

1.	Wood work, door and window frame or chowkhat,rafter beams,roof trusses,etc.	Cu m	per cu m	per cu ft
2.	Door and window shutter or leaves,panelled,battened,glazed,part panelled and part glazed,wire gauged,etc.(Thickness specified)	Sq m	per sq m	per sq ft
3.	Door and window fittings as hinges tower bolts,sliding bolts,handles,etc.	No.	per no.	per no.
4.	Timbering,boarding(Thickness specified)	sq m	per sq m	per sq ft
5.	Timbering of trenches(Area of face supported)	sq m	per sq m	per sq ft
6.	Sawing of timber	sq m	per sq m	per sq ft
7.	Woodwork in partition,ply wood,etc.	sq m	Per sq m	Per sq ft
8.	Ballies(Diameter specified)	meter	per m	per r ft
1.	Steel work- Rolled steel joists,channel,angles,T-irons,flats,squares,rounds,etc.	quintal	per q	per cwt
2.	Steel reinforcement bars,etc.,in R.C.C.,R.B work	quintal	per q	per cwt
3.	Bending,binding of steel reinforcement	quintal	per q	per cwt

4. Fabrication and hoisting of steel work.....	quintal	Per q	Per cwt
5. Expanded metal(X,P.M), size specified.....	sq m	Per sq m	Per sq ft
6. Fabric reinforcement, wire netting.....	sq m	Per sq m	Per sq ft
7. Iron work in stress...	quintal	Per q	Per cwt
8. Gusset plate (Minimum rectangular size from which cut).....	quintal	Per q	Per cwt
9. Cutting of iron Joists & channel.....	cm	Per cm	Per inch
10. Cutting Angles, Tees & Plate.....	sq m	Per sq m	Per sq inch
11. Threading in iron.....	cm	Per cm	Per inch
12.Welding,solder of sheets, plates (Welding of rails, steel, trusses, rods per no.)	cm	Per cm	Per inch
13.Boring holes in iron	no.	Per no.	Per no.
14.Cast iron(C.I) pipe, Dia. specified	metre	Per m	Per ft.
15.Rivets,Bolts and nuts,Anchor bolts,Lewis bolts,holding down bolts,etc.	quintal	Per q	Per cwt
16.Barbed wire fencing	metre	Per m	% r ft
17.Iron gate (may also be by weight,quintal)	sq m	Per sq m	Per sq ft
18.Iron hold fast (may also be by no.)	quintal	Per q	Per cwt
19.Iron railing(heigt and types specified)	metre	Per m	Per r ft
20.Iron grill,collapsible gate (may also be by weight,quintal)	sq m	Per sq m	Per sq ft
21.Rolling shutter	sq m	Per sq m	Per sq ft
22.Steel doors and windows(type and fixing specified)	sq m	Per sq m	Per sq ft
Roofing-			
1.Tiled roof ----Allahabad tile,Faizadad tile,Mangalore tile,etc. including battens	sq m	Per sq m	% sq ft
2.Country tile roof including bamboo jaffri...	sq m	Per sq m	% sq ft
3.Corrugated iron(G.C.I)roof,Asbestos cement (A.C)sheet roof	sq m	Per sq m	% sq ft

4. Slate roofing, timber roofing	Sq m	Per sq m	% sq ft
5. Thatch roofing including bamboo jaffri (Thickness specified)	Sq m	Per Sq m	% sq ft
6. Eave board (Thickness specified)	Sq m	Per sq m	% sq ft
7. R.C.C., R.B. slab roof (excluding steel)	Cu m	Per cu m	Per cu ft
8. Lime concrete roof over and inclusive of tiles, or bricks, or stones slabs, etc. (Thickness specified)	Sq m	Per sq m	% sq ft
9. Mud roof over and inclusive of tiles, or bricks, or stone slab, etc. (Thickness and type specified)	Sq m	Per sq m	% sq ft
10. Ridges, valleys, gutters, (Girth specified)	Metre	Per m	Per r ft
11. Tar felting, Bituminous painting	Sq m	Per sq m	% sq ft
12. Insulating layer in roof of sand and clay, asphalt, etc.	Sq m	Per sq m	% sq ft.
13. Expansion, contraction or construction joint...	Metre	Per m	Per r ft
14. Ceiling--- Timber, A.C. Sheet plain, cloth, Cement plaster on XPM, Paste board, etc...	Sq m	Per sq m	Per sq ft.
15. centering and shuttering Form work --- Surface area of R.C.C. or R.B. work supported (may also be per cu m (cu ft) of R.C.C. or R.B. work)	Sq m	Per sq m	% sq ft
Plastering, Pointing and Finishing :-			
1. Plastering – Cement, motar, lime motar, mud, etc. (Thickness, proportion specified).	sq m	per sq m	% sq ft
2. Pointing – Struck, flush, weather, etc.	sq m	per sq m	% sq ft
3. Dado (Thickness and type specified)	sq m	per sq m	% sq ft
4. Skirting (Thickness type and height specified)	metre	per m	per r ft
5. Cement motar or lime motar rubbing	sq m	per sq m	% sq ft
6. White washing, colour washing, cement washing (number of coat specified)	sq m	per sq m	% sq ft
7. Distemping (number of coats specified)	sq m	per sq m	% sq ft
8. Snow cement washing or	sq m	per sq m	% sq ft

finishing (number of coat specified)	sq m	per sq m	% sq ft
9. Painting, varnishing (number of coat specified)	sq m	per sq m	% sq ft
10. Polishing of wood work (number of coat specified)	no.	per no.	per no.
11. Painting letters and figures (height specified)	sq m	per sq m	% sq ft
12. Oiling and clearing of door and windows	sq m	per sq m	% sq ft
13. Coaltarring (number of coat specified)	sq m	per sq m	% sq ft
14. Removing of paint or varnish	sq m	per sq m	% sq ft
15. Gobrilepping (powderwash)			% sq ft

Flooring---			
1.2.5 cm (1") C.C over 7.5 cm (3") L.C. Floor (Including L.C.)	Sq m	Per sq m	% sq ft
2.Conglomerate floor, artificial patent stone Floor 2.5 cm (1") C.C. over 7.5 cm (3") L.C.(including L.C)	Sq m	Per sq m	% sq ft
3.4 cm (1½ ") thick stone floor over 7.5 cm (3") L.C. (including L.C)	Sq m	Per sq m	% sq ft
4.2.5 cm (1") marble flooring over 7.5 cm (3") L.C. (including L.C.)	Sq m	Per sq m	Per sq ft
5.Mosaic or terrazzo or granolithic floor over 7.5 cm(3") L.C.(including L.C.)	Sq m	Per sq m	Per sq ft
6.Brick flat floor over 7.5 cm(3") L.C. (including L.C.)	Sq m	Per sq m	% sq ft
7.Brick on edge floor over 7.5 cm (3") L.C. (including L.C.)	Sq m	Per sq m	% sq ft
8.2.5 cm (1") or 4 cm (1/2") C.C. floor	Sq m	Per sq m	% sq ft
9.Mud flooring finished gobrilepping	Sq m	Per sq m	% sq ft
10. Apron or plinth protection (may be of C.C.,L.C.,brick,etc.)	Sq m	Per sq m	% sq ft
11.Door and window sill (C.C or cement mortar plastered)	Sq m	Per sq m	% sq ft

Miscellaneous Items -			
1. Ornamental cornice (projection, type specified)	metre	per m	per r ft
2. Molding string course, drip course, beading, throating, etc.	metre	per m	per r ft
3. Ornamental pillar caps, pillar base, flowers, brackets, etc.	no.	per no.	per no.
4. Railing (Height and type specified)	metre	per m	per r ft
5. Surface drain large (item wise)-			
(i) Masonry	cu m	per cu m	% cu ft
(ii) Plastering	sq m	per sq m	% sq ft
6. Surface drain small (size, material, etc. Specified)	metre	per m	per r ft
7. Pipe – rainwater, sanitary, water pipe, etc. (Dia, Specified)	metre	per m	per r ft
8. Laying pipe line – sanitary, water pipe, etc. (Dia, depth, bedding etc. Specified)	metre	per sq m	per r ft
9. Jungle clearance	sq m or hectre	per hecter	% sq ft or per acre
10. Silt clearance in irrigation channels (similar to earthwork)	cu m	per % cu m	% cu ft
11. Trestle crate (size, type, etc. specified)	no.	per no.	per no.
12. Cleaning flues	no.	per no.	per no.
13. Cotton cords in sky light	no.	per no.	per no.
14. Easing doors and windows	no.	per no.	per no.
15. Fixing doors and windows	no.	per no.	per no.
16. Supply and fixing of hinges, tower bolts, hasp and staples, handles and hardwares, etc.	no.	per no.	per no.
17. Glazing	sq m	per sq m	Per sq ft
18. Glass panes (supply)	sq m	per sq m	Per sq ft
19. Fixing of glass panes or cleaning	no.	per no.	Per no.
20. Renewing of glass panes	no.	per no.	per no.
21. Well sinkling(masonry or tube well)	metre	per m	per r ft
22. Pile driving or sinking	metre	per m	per r ft
23. Furnitures – chairs, tables, etc. (size, shape specified)	no.	per no.	per no.

24..Painting furniture	no	Per no	Per no
25.Caning chairs	no	Per no	Per no
26.Pitching of brick, stone,kankar,etc	cu m	Per cu m	% cu ft
Li channel,tunnel etc.(Brick pitching may also be on area in sq m)			
27.Lining of irrigation channel,tunnel ,etc.materials ,thickness specified	Sq m	Per sq m	% sq ft
(Thick lining may be in volume basis in cu m)			
28.Kankar quarrying kankar supply	Cu m	Per cu m	% cu ft
29.Kankar consolidation ,road metal consolidation	Cu m	Per cu m	% r ft
30.Dag belling (May also be per km)			
31.Bituminous road surfacing	Sq m	Per sq m	% sq ft
32. Dismanting-----	- Cu m	- Per cu m	- % sq ft
33. Distaming of brick masonry			
34.Grouting(Bituminous grouting of road metal,cement grouting of concrete)	Sq m Metre	Per sq m Per m	% sq ft Per r ft
35.Grouting of cracks ,joints,etc.			
36.Electric wiring of electrifaction light ,fan,plug points	Point	Per point	Per point
37.Watercloset(W.C)Wash hand basin,manahole,etc.	No.	Per no.	Per no.
Materials-----	% nos.	Per % nos.	% nos.
1. Supply of bricks	Cu m	Per cu m	% cu ft
2. Supply of sand,surkhi,cinder,etc.	Bag of 50 kg.	Per bag or	cwt Per
3. Supply of cement... ..4. Supply of lime unslaked	Quintal Quintal	Per quintal Per quintal	maund Per maund
5. Supply of time slaked (may also be in volume basis in cu m)	Cu m	Per cu m	% cu ft
6. Supply of brick ballast, stone ballast, aggregate, etc.	Cu m	Per cu m	% cu ft
7.Broken bricks, kankar, etc.			
8. Supply of timber	Cu m	Per cu m	% cu ft
9. Supply of steel	Quintal	Per q	Per cwt
10. Supply of bitumen, tar	Tonne	Per tonne	Per ton
11. Supply of coal	Tonne	Per tonne	Per ton
12. Supply of A.C.sheets	Sq m	Sq m	Sq ft
13. Supply G.I. sheet	Quintal	Per quintal	Per cwt
14. Supply of switches, plugs	No.	Per no.	Per no.
15. Supply of insulated electric	Quintal	Per quintal	Per cwt
	Quintal	Per quintal	Per cwt

wire			
16. Supply of bare electric wire	No.	Per no.	Per no.
17. Tents, sholdaries	No.	Per no.	Per no.
18. Supply of W.C.	no.	Per no.	Per no.
19. Supply of wash hand basin (size specified)	no.	Per no.	Per no.
20. Supply of cowl, mica valve, interseping trap, etc. (size specified)	no.	Per no.	Per no.
21. Supply of bibcock, stopcock, ballcock, etc. (size specified)	no.	Per no.	Per no.
22. Ferrule, C.I. tank, water metre, etc.	Metre	Per m.	Per r ft
23. supply of pipe, C.I. pipe, S.W. pipe. Hume pipe, A.C. pipe, G.I. pipe, etc. (diaspecified)	Kq or quintal	Per kq	Per cwt
24. Supply of lead, lead wool	Kg	Per kg	Per lb
25. Spunyarn			
26. Supply of varnish, oil, etc.	Ltre	Per litre	Per gl
27. supply of paint readymix	Litre	Per litre	Per gl
28. Supply of stiff paint	Kg	Per kg	Per lb
29. Explosive for blasting	kg	Per kg	Per lb

Estimation of materials in single storeyed flat roof building

Example 1: From the given figure below calculate the detailed and abstract estimate for the single roomed building (Load bearing type structure) by
 a) long wall & short wall method (b) Centre Line Method

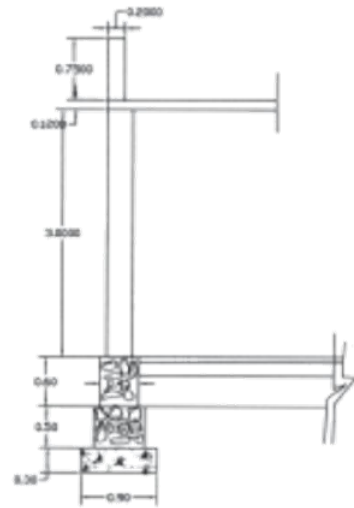
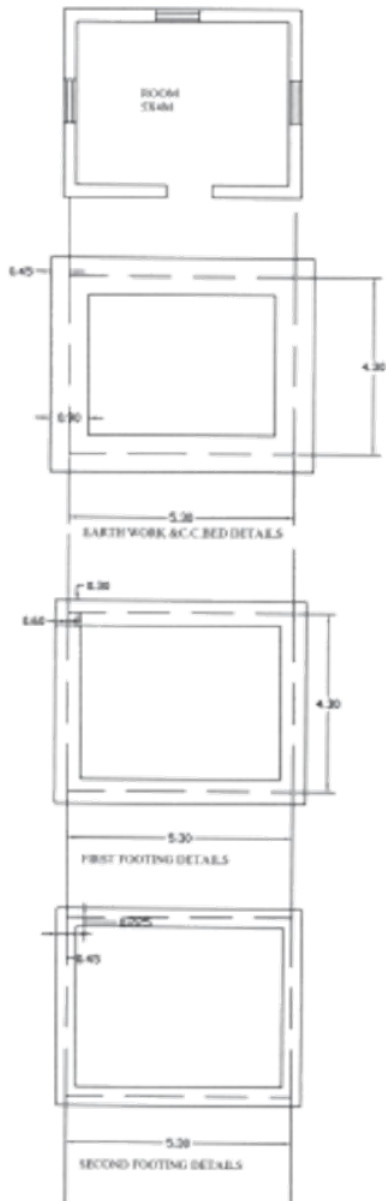

cross section at X-X

Note: All Dimensions are in 'M'

D=1X2.1M

W=1.5X1.2M

S.No.	Particulars of Items	No.	L	B	H	Q	Explanation	
1	Earth Work excavation for foundation a) Long walls b) Short walls	2	6.2	0.9	1.4	15.264	L=5.3+.45+.45 =6.2 D=0.3+0.5+0.6= 1.4 L= 4.3-0.45-0.45= 3.4 M ³	
		2	3.4	0.9	1.4	8.568		
								24.192
2	C.C.(1:4:8) bed for foundation a) Long walls b) Short walls	2	6.2	0.9	0.3	3.348	m ₃	
		2	3.4	0.9	0.3	1.836		
								5.184
3	R.R.Masonry in CM (1:6) for a) Footings i) Long walls ii) Short walls b) Basement i) Long walls ii) Short walls	2	5.9	0.6	0.5	3.54	L= 5.3+0.3+0.3=5.9 L=4.3-0.3-0.3 = 3.7 L= 5.3+0.225+0.225= 5.75 L=4.3-0.225-0.225 =3.85 m ³	
		2	3.7	0.6	0.5	2.22		
		2	5.75	0.45	0.6	3.105		
		2	3.85	0.45	0.6	2.079		
4	Brick masonry with CM (1:6) for super structure a) Long Walls b) Short walls c) for parapetwall a) Long Walls b) Short walls Deductions for openings a) Doors b) Windows Net Brick Masonry	2	5.6	0.30	3.00	10.08	L=5.3+0.15+0.15=5.6 L=4.3-0.15-0.15=4.0 m ₃	
		2	4.0	0.30	3.00	7.20		
		2	5.6	0.2	0.75	1.68		
		2	4.4	0.2	0.75	1.32		
		1	1.0	0.3	2.1	0.63		
		3	1.5	0.3	1.2	1.62		
5	R.C.C. (1:2:4) for a) Roof slab b) Lintels over i) Doors ii) Windows c) Beams i) Long beams ii) short beams	1	5.6	4.6	0.12	3.090		
		1	1.2	0.3	0.15	0.054		
		3	1.5	0.3	0.15	0.202		
		2	5.6	0.3	0.3	1.008		
		2	4.0	0.3	0.3	0.720		

					Total	5.074	m₃
6	Sandfilling for basement	1	4.85	3.85	.48	8.96	L=5.0-0.075-0.075=4.85
7	C.C.(1:4:8) for flooring	1	4.85	3.85	0.1	1.86	B=4.0-0.075-0.075=3.85
8	Flooring with Mosaic tiles	1	5.0	4.0	--	20.0	m₂
9	Plastering with CM (1:6)for super structure						
	<u>Inside</u>	1	18.0	--	3.0	54.0	
	For walls						
	<u>Out side</u>	1	20.4	--	3.87	61.2	
	For walls						
	Basement outside	1	21.6	--	0.6	12.96	
	<u>Parapet wall</u>						
	a) Inside	1	18.8	--	0.75	14.1	
	b) top	1	19.6	0.2	---	3.92	
	<u>Deductions for openings</u>						
	Doors	1x2	1.0	--	2.1	4.2	
	Windows	3x2	1.5	--	1.2	10.8	
	Net Plastering					131.18	m₂
10	Plastering for Ceiling With CM(1:5)	1	5.0	4.0	--	20.0	m₂
11	White Washing with Two coats with cement Same as quantity of plastering for walls and ceiling					151.18	(=131.18+20=151.18)
12	Colour washing with two coats Same as quantity of plastering for walls and ceiling					151.18	(=131.18+20=151.18)
13	Supply & Fixing of best country wood for a) Doors b) Windows	1 3				1 No. 3No	
14	Painting with ready mixed synthetic enamel paints with two coats over primary coat for new wood for a) Doors b) Windows	2¼x1 2¼x3	1.0 1.5	--- ---	2.1 1.2	4.725 12.15	

					Total	16.875	m₂
15	Petty supervision and contingencies at 4% and rounding off.						

b) centre line method

Sl. No.	Particulars of Items	No.	L	B	H	Q	Explanation
1.	Earth Work exevation for foundation	1	19.2	0.9	1.4	24.192	$L=2(5.3+4.3)=19.2$ m₃
2	C.C.(1:4:8) bed for foundation	1	19.2	0.9	0.3	5.184	m₃
3	R.R.Masonry in CM (1:6) for a) Footings b) Basement	1 1	19.2 19.2	0.6 0.45	0.5 0.6	5.76 5.184	
					Total	10.944	
4	Brick masonry with CM(1:6)for super-structure For parapet wall Deductions for openings a)Doors b) Windows Net Brick Masonry =	1 1 1 3	19.2 20.0 1.0 1.5	0.3 0.2 0.3 0.3	3.0 0.75 2.1 1.2	17.28 3.00 0.63 1.62	m₃ 18.03 m₃
5	R.C.C. (1:2:4) for a) roof slab b) Lintels over i) Doors ii) Windows c) beams	1 1 3 1	5.6 1.2 1.5 19.2	4.6 0.3 0.3 1.3	0.12 0.15 0.15 0.3	3.090 0.054 0.202 1.728	Total 5.074 m₃
6	Sandfilling for basement	1	4.85	3.85	0.48	8.96	$L=5.0-0.075-0.075=4.85$
7	C.C.(1:4:8) for flooring	1	4.85	3.85	0.1	1.86	$B=4.0-0.075-0.075=3.85$
8	flooring with Mosaic tiles	1	5.0	4.0	--	20.0	
9	Plastering with CM (1:6)for super structure Inside For walls Out side	1	18.0	--	3.0	54.0	

	For walls	1	20.4	--	3.87	61.2	
	Basement outside	1	21.6	--	0.6	12.96	
	Parapet wall						
	a) Inside	1	18.8	--	0.75	14.1	
	b) top	1	19.6	0.2	---	3.92	
	<u>Deductions for</u>						
	<u>opeinings</u>						
	Doors	1x2	1.0	--	2.1	4.2	L=5.0-0.075-0.075=4.85
	Windows	3x2	1.5	--	1.2	10.8	B= 4.0-0.075-0.075=3.85
	Net Plastering =					131.18	m₂
10	Plastering for Ceiling With CM(1:5)	1	5.0	4.0	--	20.0	m₂
11	White Washing with two coats with cement Same as quantity of plastering for walls and ceiling					151.18	m₂ (131.18+20=151.18)
12	Colour washing with two coats Same as quantity of plastering for walls and ceiling					151.18	m₂ (131.18+20=151.18)
13	Supply & Fixing of best country wood for a) Doors b) Windows	1 3				1 No. 3No	
14	Painting with ready mixed synthetic enamil paints with two coats over primary coat for new wood for a) Doors b) Windows	2¼x1 2¼x3	1.0 1.5	--- ---	2.1 1.2	4.725 12.15	
					Total	16.875	m₂
15	Petty supervision and contingencies at 4% and rounding off						

Abstract estimate of single roomed building (load bearing structure)

S.No	Description of item	Quantity	Unit	Rate	Per	Amount
1.	Earth work excaation	24.192	m ₃	465	10m ₃	1125.00
2.	Cement concrete(1:4:8)	5.184	m ₃	4545	1m ₃	8009.30
3.	RR.masonry in C.M.(1:5)	10.94	m ₃	1391	m ₃	15217.50
4.	Sand filling in basement	8.96	m ₃	195.20	10m ₃	175.00
5.	Brick masonry in country bricks of standard size in CM(1:8)	18.03	m ₃	2291	m ₃	41306.73
6.	R.C.C. (1:2:4) for lintels, beams etc.	1.984	m ₃	6030	m ₃	11963.52
7.	R.C.C.(1:2:4) for slabs,	3.09	m ₃	6030	m ₃	18633.00
8.	Cement concrete (1:5:10) for flooring	1.86	m ₃	1452	m ₃	2700.72
9.	Supplying and fixing of country wood for doors.	2.1	m ₂	1650	m ₂	3465.00
10.	Supplying and fixing of country wood for windows and ventilators.	5.4	m ₂	2300	m ₂	12420.00
11.	Plastering to all exposed surfaces of brick work and basement with C.M (1:5)	151.18	m ₂	582	10m ₂	8798.70
12.	White washing with best shell lime	151.18	m ₂	116	10m ₂	1753.68
13.	Flooring with spartek tiles set in C.M (1:3)	20	m ₂	4230	10m ₂	8460.00
14.	Painting with ready mixed enamel paint	16.875	m ₂	335	10m ₂	565.31
15.	Povision for water supply and sanitary arrangements @12.5%				Total	134593.46
16.	Provision for electrification @7.5%					16824.18
17.	Provision for architectural appearance @2%					10094.50
18.	Provision for unforeseen items 2%					2691.86
19.	Provision for P.s.and contingencies @4%					2691.86
						5383.73
Grand Total Rs.						172279.65

Culvert and Bridge :-

According to I.R.C. specification, a culvert is one which has a linear waterway upto 6m and structures having a linear waterway above 6m but below 30m are Minor Bridges and structures having a linear waterway of 30m or more are Major Bridges.

As a general rule, a minimum of 6m of linear waterway should be provided per 15.km of the road for efficient drainage.

Some Common terms –

- (a) Abutment :- It is a masonry or oriented concerned wall that constitutes the end support of bridges or similar structures by which it joins the bank of waterway.
- (b) Wing wall :- Wing wall is a retaining wall which sustains the embankments of the approaches where they join the bridge.
- (c) Return wall :- A return wall is retaining wall built parallel to the centre line of a road to retain the embankment.
- (d) Curtain walls :- Cross walls are built across the stream on the up-stream or down-stream in order to protect the structure from erosion due to strong current of water induced by the restriction of free passage of water through the water way.

Process of calculations of earth work for (1) Abutment, (2) Wing and (3) Curtain walls (when provided) :-

- (1) Abutments 2nos. = $2 \times \text{Area ABCD} \times \text{depth of excavation.}$
- (2) Wing walls 4nos. = $4 \times \text{Area BEFG} \times \text{depth of excavation.}$
- (3) Curtain walls 2nos. = $2 \times \text{Area MNPQ} \times \text{depth of excavation.}$

Curtain walls at the two ends of Abutment walls are not always provided.

Process of calculations to estimate quantities of earthwork, concrete work and masonry work for (1) Abutments, (2) Wing walls and (3) Return walls of a splayed Culvert or Bridge :-

(1) **Abutments** :- For each or concrete work :-

(a) Length = Road width + 2 (parapet thickness + one side end efforts).

End offsets for one end = Summation of inner foundation offsets + offset due to inner battering if any.

(b) Breadth and depth are shown in the section of the abutment.

For Masonrywork below G.L.

(a) Length = Same as concrete work as above – 2 x offset of concrete.

Length for each individual offset differ and should be calculated individually by deduction of the projections from the each end.

(b) Breadth and depth for each individual offset are shown in the section of the abutment. For masonrywork above G.L.

(i) With vertical inner face :-

(a) Length = Roadwidth + 2parapet thickness (outer face battering should not be accounted if any).

(b) Breadth and depth are as shown in the section.

(ii) With battered inner face :-

When the inside the face of Abutment is continued to wing wall the extra bottom length due to batter may be considered as if included in the wing wall i.e. the two walls join on a vertical plane.

(a) Length = Road width + 2 parapet thickness.

When the width of Abutment at the ends is not equal to the inclined width of the wing wall joining with abutment-1s as shown in fig 10-28.

Length = $\frac{1}{2}$ (Top length + Bottom length).

Bottom length – Top length + 2 x offset due to inner batter face of Abutment.

(2) Wing walls :- The thickness and height of the wall is maximum at the junction with its abutment and both the dimensions are gradually reduced to the section as that at return wall with which it joins.

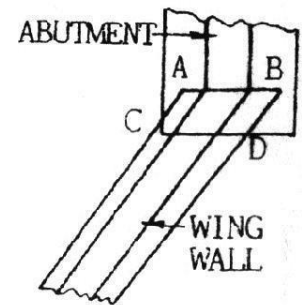

FIG. 10-28

For earth or correct work

Following Fig. 10-29 consider the end of excavations is up to the line R.S.
We have to find out the quantity for the are ADSR.

- (a) Length = $Y +$ offsets from the outer edge of return wall
- (b) Breadth = $\frac{1}{2} + (AD+RS)$;

AD is the inclined trench width of wing wall parallel to the centre line of the road and generally the trench width of the abutment. If not equal, the offset (as shown in Fig. 10-28) is mentioned.

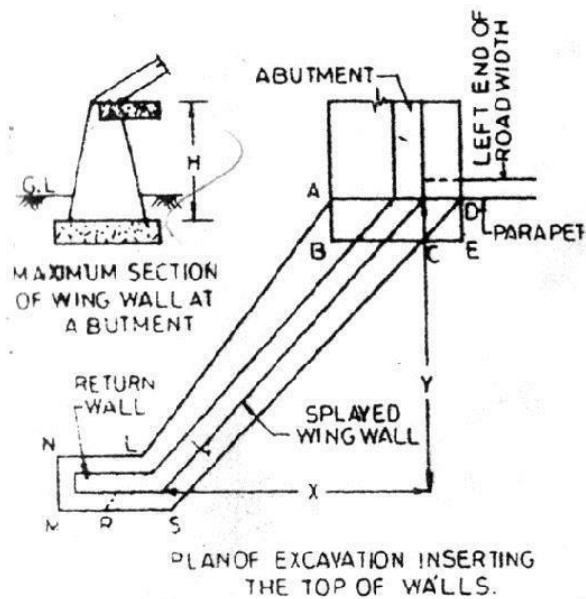

FIG. 10-29

RS = Inclined foundation trench width of Return wall parallel to the centre line of the road.

$$= \text{Foundation width of Return wall} \times \sqrt{\sum \text{sq. of prop. of splay.}}$$

Usually, the proportion of splay X : Y = 1:1 (for 45°)

$$\sqrt{\text{sq. of of splay}} = \sqrt{1^2 + \sqrt{1^2}} = \sqrt{2}$$

Thus when the ratio X : Y = 1:1/2 then the multiplying factor = $\sqrt{1^2 + 1.5^2} = 1.80$

Depth = usually the same depth of excavation as that of abutment is provided.

Deduction for end offset of Abutment :-

During excavation for Abutment the portion ABCD (see fig. 10-29) has already been excavated. Therefore, the volume of work for this portion should be deducted from the volume of work for the wing wall : Now AD = Foundation width

$$BC = AD - CE; CE = DE \times X/Y$$

. .Deduction for Abutment offset = $\frac{1}{2} \times [\text{trench width} + (\text{trench width} - \text{offset} \times X/Y)]$

x depth.

For concrete work the depth of concrete instead of depth earthwork shall be considered.

For masonry work below G.L.

- (a) Length = Y + offset of masonry in foundation of return wall
- (b) Breadth = same process as that of earthwork
- (c) Depth = thickness of the footing.

The construction of wingwall may be with its battered inner and outer faces starting from the top of the foundation concrete up to top. In such cases the whole mass shall be calculated in one operation considering this as Frusta of Pyramid, erected vertically on AD as base.

Volume = $\frac{h}{3} (A_1A_2 + \sqrt{A_1A_2})$ where A_1 and A_2 are areas of ends, i.e. vertical sectional area.

At Abutment and at the end ; h is the measurement of Y.

Deduction for end offsets of Abutment :- Following the same procedures as in the case of earthwork deduction for Abutment offset for the corresponding footing of wing wall = $\frac{1}{2} \times$ [width of Abut. Footing + (width of Abut footing – projection \times X/Y)] \times depth. The projection is form top face of the Abutment up to the edge of the corresponding footing.

For masonrywork above G.L.

Wing walls above G.L. may have the following shapes :- (i) Inside face vertical or battered but at the outer face with offsets; (ii) Both the faces are battered.

- (i) Inside face vertical with offsets at the outer face :- Before starting the estimate, let us clarify how offsets are provided at the outside face of the wing wall. Let the top plan of wall is ABCD with three offsets, D_1 D, E_1 E and F_1 F of lengths L_1 , L_2 and L_3 respectively as shown in Fig . 10-30.

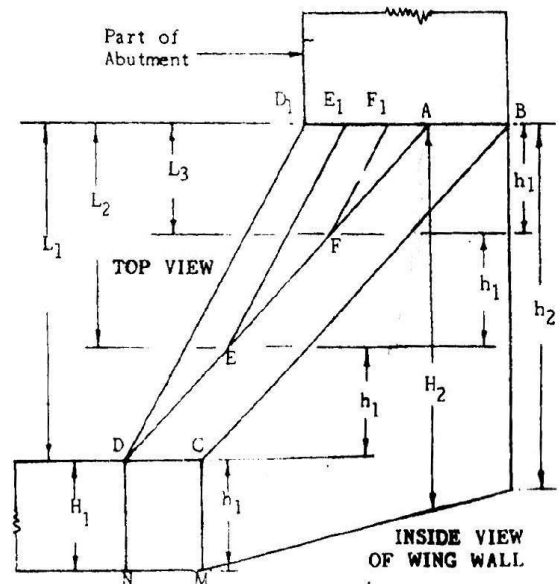

FIG. 10-30

The height of the wingwall is h_1 at the end and h_2 at Abutment.

The top of ABCD of the wing wall is sloped downward uniformly from AB to DC.

To have a clear picture regarding the shape of the outside offsets suppose we are to reach the inclined level AF of the from the left side ground level.

For this purpose three numbers steps ADD_1 , AEE_1 and AFF_1 are constructed with uniform rise h_1 , when $h_2 = 4h_1$

The second step AEE_1 is constructed over the first step ADD_1 and similarly the third

step AFF_1 over AEE_1 . Now by crossing the three steps from the left we have reached to the height of $F = 3h_1$. The difference of level between the points F and A is also h_1 .

But, actually these triangular steps are known as offsets of the wing wall. The projections are shown on plan and height on elevation drawn by the side of section of the Abutment. The purpose of these offset is to strengthen the core part ABCD of the wing wall.

Masonrywork above G.L. excluding offsets but including inside batter :-

Considering the mass as Frusta of Pyramid, $V = \frac{h}{3} (A_1 + A_2 + \sqrt{A_1 A_2})$. The notations are same as given before. When there be no battered at the inside face, the volume for the rectangular mass within the same inclined width through its length shall be calculated for different height at the ends by ordinary method, i.e., average depth x inclined breadth x straight length.

$$\text{Vol. of 1st offset} = \frac{h}{2} L_1 \times AD_1 \times h_1,$$

$$\text{Vol. of 2nd offset} = \frac{h}{2} L_2 \times AE_1 \times h_1 \text{ and}$$

$$\text{Vol. of 3rd offset} = \frac{h}{2} L_3 \times AF_1 \times h_1.$$

Deduction of Abutment offset :-

When the width of Abutment at the ends is not equal to the inclined width of the wing wall as the well as the inside face of the Abutment is battered then the length of the Abutment includes the offsets at the end. In this case deduction for the offset projection is made from the volume of wing wall.

Return wall :-

Length = Average length for the RMNL = $\frac{1}{2} (RM + NL)$

RM = MS

NL = RM + MN x- MN is the trench width.

Details of Measurements and Calculation of Quantities.

S.No.	Particulars of Items	No.	L	B	H	Q	Explanation
1	Earthwork in excavation in foundation Abutments Wing walls	2 4	5.10 1.20	0.70 0.70	0.60 0.60	4.28 2.02	
					Total	6.30	m³
2	Cement concrete 1:3:6 In foundation with stone ballast- Abutments Wing walls	2 4	5.10 1.20	0.70 0.70	0.30 0.30	2.14 1.01	(1/2) of earthwork in excavation in item 1 m³
					Total	3.15	m³
3	I-class brickwork in 1:4 cement mortar- Abutments Wing walls Parapets up to kerb	2 4 2	4.8 1.2 4.7	0.4 0.4 0.4	1.5 1.5 0.3	5.76 2.88 1.13	(Up to top of RCC slab) (Above RCC slab up to Kerb)
	Parapets above kerb Parapets coping	2 2	4.7 4.9	0.3 0.4	0.5 0.1	1.41 0.39	(Above kerb excluding coping.)
	Deduct Bearing of R.C.C. slab in abutment	2	4.8	0.3	0.2	0.57	
					Total	11.57	
					Total	11.00	m³
4	R.C.C. work 1:2:4 in Slab excluding steel and its bending centering shuttering and binding steel	1	4.8	2.1	0.2	2.016	m ³ no deduction for volume of steel.
5	Steel bar including bending in RCC work- 20 mm dia. Bars- Main straight bars 30 cm c/c {No= (4.8/0.30) +1=17} Main bent up bars 30 cm c/c {No. = (4.80/0.30)=16} 10mm Dia. Bars- Distributing bottom bars 25 cm c/c Distributing top bars Total 63.70m @ 0.62kg=	17 16 9 4	2.38 2.54 4.90 4.90	-- -- -- --	-- -- -- --	40.46 40.64 44.10 19.60	L=2.10-2side covers + 2hooks= 2.10- (2x4cm)+(18x20mm) =2.38m Adding one depth, 16 cm for two bent ups L=2.38+0.16=2.54m L=4.80-2end covers+ 3hooks = 4.80- (2x4cm)+(18x10mm) =4.90m
						39.49	kg
6	Cement concrete 1:2:4 wearing coat	1	4.00	2.30	0.10	0.92	In between parapets cu.m
7	Cement pointing 1:2 in						

walls- Face wall from 10 cm below G.L. up to bottom of coping inner side of parapet excluding coping	2	4.70	--	2.10	19.74	Ht.=(20+10+50))=0.80 B=(10+40+10+ 10)cm=.70m Up to kerb. Above kerb Edge and under side
	2	4.70	--	0.80	7.52	
	2	4.90	.70	--	6.86	
	4	--	.40	.20	.32	
	4	--	.30	.50	.60	
	4	--	.40	.20	.32	
	Deduct- Rectangular opening	2	1.50		Total 1.30	
Triangular portion below earth slope	2	-X1.3	X1.3	Total Dedu ction Total	1.69 N5.59 29.77	edge of RCC slab Sq m

Abstract of Estimated cost of Bridge

S.No	Description of item	Quantity	Unit	Rate	Per	Amount Rs. P.
1	Earthwork in excavation in foundation	6.30	Cu m	350.00	Cu m	22.05
2	Cement concrete 1:3:6 in foundation with stone ballast	3.15	Cu m	400.00	Cu m	1260.00
3	I-class brickwork in 1:4 cement mortar	11.00	Cu m	365.00	Cu m	4015.00
4	R.C.C. work 1:2:4 in slab excluding steel and its bending but including centering, shuttering and binding steel	2.016	Cu m	775.00	Cu m	1562.40
5	Steel bar including bending in R.C.C work	2.398	Quintal	515.00	Quintal	1234.97
6	Cement concrete 1:2:4 in wearing coat	0.92	Cu m	450.00	Cu m	414.00
7	Cement pointing 1:2 in wall	29.77	Sq m	5.60	Sq m	166.71
					Total	8675.13
	Add 5%(3% for contingencies and 2% for work-charged Establishment)					433.75
				Grand Total		9108.88

Module – II

Under

Module-II

WHAT IS SPECIFICAT.....

Exact statement of the particular needs to be satisfied, or essential characteristics that a customer requires (in a good, material, method, process, service, system, or work) and which a vendor must deliver. Specifications are written usually in a manner that enables both parties (and/or an independent certifier) to measure the degree of conformance. They are, however, not the same as control limits (which allow fluctuations within a range), and conformance to them does not necessarily mean quality (which is a predictable degree of dependability and uniformity).

Specification for various types building works

GENERAL SPECIFICATION OF A FIRST CLASS BUILDING

Foundation and plinth foundation and plinth shall be of 1-class brick work in lime mortar or 1:6 cement mortar over lime concrete or 1:4:8 cement concrete

Damp proof course

D.C.P shall be 2.5 cm thick cement concrete 1:1:3, mixed with one kg of imperious per bag of cement or other standard water proofing materials as specified and painted with two coats of bitumen

Superstructure

Superstructure shall be of 1-class brickwork with lime mortar or 1:6 cement mortar. lintels over doors and window shall be of R.C.C

Roofing

Roof shall be of R.C.C slab with an insulation layer and lime concrete terracing above, supported over R.S joist or R.C.C beam as required. Height of rooms shall not be less than 3.7m(12 feet)

Flooring

Drawing room and dining room floors shall be of mosaic. Bathroom and W.C floors and dado shall be mosaic. Floors of bedrooms shall be colored and polished of 2.5 cm cement concrete over 7.5 cm lime concrete. Floors of other shall be of 2.5 cm cement concrete over 7.5 cm lime concrete polished.

Under

Finishing

Inside and outside walls be of 12mm cement lime plastered 1:1:6. Drawing ,dining and bedrooms –inside shall be distempered ,and other –inside white washed 3 coats. Outside shall be colored snowcem washed two coats over one coat of white wash.

Doors and windows

chaukhats shall be seasoned teak wood. Shutters shall be teak wood 4.3 cm thick paneled glazed or partly glazed as required, with additional wire gauge shutters. All fittings shall be of brass. Doors and windows shall be varnished or painted two coats with high class enamel paint over one coat of priming. Window shall be provided with iron gratings or grills.

Miscellaneous

Rain water pipes of cast iron or of asbestos cement shall be provided and finished painted. Building shall be provided with 1st class sanitary and water fittings and electrical installations. 1 meter wide 7.5 cm thick C.C 1:3:6 apron shall be provided all all round the building

General specifications of a second class Building

Foundation and plinth-Foundation and plinth shall be of 1st class brickwork with lime mortar over lime concrete.

Damp proof course-D.P.C. shall be of 2 c.m (3/4") thick cement concrete 1:2 mixed with 1 kg of imperious per bag of cement or other standard water proofing materials.

Superstructures-Superstructures shall be of 2nd class brickwork in lime mortar. Lintels over doors and windows shall be of R.B.

Roofing-Roof shall be R.B. slab with 7.5 cm lime concrete terracing above (or flat terraced roof supported over wooden battens and beams ,or Jack arch roof). Verandah roof may be of A.C. sheet or Allahabad tiles.

Flooring-Floors shall be 2.5 cm (1") cement concrete over 7.5 cm (3") L.C. Verandah floor shall be of brick tile or flag stone over lime concrete, finished cement painted.

Finishing-Inside and outside walls shall be of 12 mm cement mortar plastered 1:6 ceiling shall be cement plastered 1:3 inside shall be white washed 3 coats, colour washed two coats over one coat of white wash.

Doors and windows-Chaukhat shall be of R.C.C. or well seasoned sal wood shutters of shisham wood or deodar wood 4 cm(1 1/2") thick, panelled, glazed or partly panelled and partly glazed as required, fitted with iron fittings with iron fittings. Doors and windows shall be painted two coats over one coat of priming.

Under

Miscellaneous-Rain water pipes shall be of cast iron finished painted. Electrification, and sanitary and water fittings' may be provided if required.

GENERAL SPECIFICATION OF 3RD CLASS BUILDING:

❖ FOUNDATION AND PLINTH:

- Foundation and plinth shall be of 2nd class brick work in lime mortar in a lime concrete. Damp proof course shall be 2cm thick cement mortar 1:2 mixed with standard water proofing compound.

❖ SUPER STRUCTURE:

Superstructure shall be second class brick work in mud mortar. Door and window opening shall be provided with arches of 2nd class brick work in lime mortar.

❖ ROOFING:

Roof shall be of mud over tiles or brick or G.I sheet or A.C. sheets sloping roof.

❖ FLOORING

Floor shall be of brick-on-edge floor over well rammed earth.

❖ FINISHING

Inside and outside wall shall be plastered with lime mortar and white washed three coat.

❖ DOORS AND WINDOWS

Chaukhat shall be salwood, and shuttered of chir mango or other country wood.

SPECIFICATION OF 4TH CLASS BUILDING

❖ FOUNDATION AND SUPER STRUCTURE:

Foundation and superstructure shall be of sun-dried in mud mortar. Door and window opening shall be provided with arches of 2nd class brick work in lime mortar or with wooden plank.

❖ ROOFING

Roofing shall be of tile roof over bamboo and wooden supports.

❖ FLOORING

Floor shall be kutcha or earthen floor finished with "gobri" washing.

❖ DOOR AND WINDOW

Door and window shall be chir or mango wood.

What is detailed Specification.

- ❖ The detailed specification is a detailed description and expresses the requirements in detail.
- ❖ The detailed specification of an item of work specifies the qualities and

Under

quantities of materials, the proportion of mortar, workmanship, the method of preparation and execution and methods of measurement.

- ❖ The detailed specification of different items of work is prepared separately, and describes what the works should be and how they shall be executed & constructed.
- ❖ Detailed specifications are written to express the requirements clearly in a concise form avoiding repetition & ambiguity.
- ❖ The detailed specification is arranged as far as possible in the same sequence of order as the work is carried out.
- ❖ The detailed specifications if prepared properly are very helpful for the execution of work.
- ❖ The detailed specifications form an important part of contract document.
- ❖ Every engineering departments prepares the detailed specifications of the various items of works, & get them printed in book form under the name 'Detailed specifications.'
- ❖ When the work , or a structure or project is taken up, instead of writing detailed specification every time, the printed Detailed Specifications are referred

Earthwork in excavation in foundation

➤ **Excavation:**

Foundation trenches shall be dug out to the exact width of foundation concrete & the sides shall be vertical.

If the soil is not good & does not permit vertical sides, the sides should be sloped back or protected with timber shoring.

Excavated earth shall not be placed within 1m (3') of the edge of the trench.

➤ **Finish of trench:**

The bottom of foundation trenches shall be perfectly levelled both longitudinally & transversely & the sides of the trench shall be dressed perfectly vertical from bottom up to the least thickness of loose concrete so that concrete may be laid to the exact width as per design.

➤ **Finds:**

Any treasure & valuables or materials found during the excavation, shall be property of the government.

➤ **Water in foundation:**

Water, if any accumulates in the trench, should be bailed or pumped out without any extra payment & necessary precautions shall be taken to prevent surface water to enter into the trench.

Under

➤ **Trench filling:**

After the concrete has been laid masonry has been constructed the remaining portion of the trenches shall be filled up with earth in layers of 15cm (6") watered & well rammed . The earth filling shall be free from rubbish & refuse matters & clods shall be broken before filling. Surplus earth not required, shall be removed & disposed, & site shall be levelled & dressed

➤ **Measurement:**

the measurement of the excavation shall be taken in cu m(cu ft) as for rectangular trench bottom width of concrete multiplied by the vertical depth of foundation from ground level & multiplied by the vertical depth of foundation from ground level & multiplied by the length of trenches even though the contractor might have excavated with sloping side for his convenience.

Rate shall be for complete work for 30m(100ft) lead & 1.50m(5')lift, including all tools & plants required for the completion of the works. For every extra lead of 30 m & every extra lift of 1.5m separate extra is provided.

➤ **Excavation :**

Excavation in saturated soil or below sub soil water level shall be taken under a separate item & shall be carried out in the same manner as above.

Pumping or bailing out of water & removal of slush shall be included in the item. Timbering of the sides of trenches if required shall be taken under a separate item & paid separately.

Detailed specification of lime concrete in foundation

Definition

A concrete made from a mixture of lime, sand, and gravel is said to be as lime concrete. It was widely used before the lime was replaced by Portland cement.

Lime as the first cement

Since long, Lime has been used to make things like plaster and mortar. Lime is usually made by burning of limestone. Chemically; lime itself is calcium oxide (CaO) and is made by roasting calcite (CaCO₃) to remove carbon dioxide (CO₂).

Lime is also called calx or quicklime. Quick Lime is very caustic and can even dissolve human bodies.

Under

When lime is mixed with water, lime slowly turns into the mineral portlandite (dense) in the reaction $\text{CaO} + \text{H}_2\text{O} = \text{Ca}(\text{OH})_2$. Lime is mixed with an excess of water so it stays fluid, this is called slaking and the lime resulting is called slaked lime. Slaked lime continues to harden over a period of weeks. Lime has to be mixed with sand and other ingredients to take form of slaked lime cement, that can be used as mortar between stones or bricks in a wall or spread over the surface of a wall. There, over the next several weeks or longer, it reacts with CO_2 in the air to form calcite again (artificial limestone)

Concrete made with lime cement is well known from more than 5000 years old. It was widely used in all over the world. Sign of its usage can be found easily after surveying different archaeological sites. In dry conditions, it works extremely well.

Manufacturing of lime

Lime is usually manufactured by burning limestone, in the process driving off carbon dioxide leaving the clinker of calcium oxide and quick lime. When quick lime is slaked with water, it disintegrates into fine grained powder depending on the volume of water added. The pure slaked lime formed in this way is said to be as fat lime. It can be used for construction of masonry but it hardens quickly in air. Masonry buildings that were built in the past by with fat lime are now demolished as their strength is very less than the strength when lime concrete was placed.

Hydraulic lime is one of the advanced form of fat lime. It is manufactured by addition of fat lime with surkhi (clay rich in silicates). Hydraulic lime can be made into satisfactorily mortar that achieves strength similar to that of cement mortar.

Preparation of lime concrete

The main ingredient of this concrete is slaked lime as binding material. The slaked lime is obtained in various forms as hydrated lime powder, lime putty, slaked lime slurry that is prepared by grinding in suitable Grinding Mills. Slaked lime is first mixed with sand to prepare lime mortar which is then further mixed with coarse aggregates, in suitable proportion. For preparation of lime concrete, first hard impervious level base is prepared by stones or brick pitching. Then quantity of sand is spread as the horizontal base. Generally lime & sand are taken in ratio of 1:1 to 1:3 by volume. Measured quantity of slaked lime is then added to sand and then mixing is done. In this mixing, water is sprinkled continuously to make the whole mass plastic.

Then the whole mass is allowed to mature for 1 to 3 days. After that coarse aggregates of desired type are used to lay on the prepared hard impervious level surface. After that lime mortar which is made with sand & lime is introduced into the base. Sufficient water is sprinkled over the base and it is cut into the layers and then is turned upside down with the help of spade or shovel until the whole assembly has become uniform.

Laying of lime concrete

The base where lime concrete is to be laid is prepared by cleaning, levelling and

Under

compacting by ramming properly. The material is laid on prepared foundation bases and rammed manually with steel rammer. During ramming water may be sprinkled if concrete is dry and stiff. After that it is cured for 7 to 14 days.

Properties of lime concrete

Lime concrete provides good bases to bear the sufficient loads and also provide certain degree of flexibility. It adjusts very well when it is in contact with surface. Lime concrete also exhibits certain degree of water proofing property and thus prevents subsoil dampness in floors and walls. Lime concrete also exhibits volumetric stability. It can be made easily and can be available at much cheaper rates. It also resists weathering effects and is very durable.

Drawbacks of Lime concrete

1. Hydraulic lime usually gains strength in time greater than the time in which cement concrete gains same value of strength.
2. Lime cement takes a long time to cure, and while the ancient world had lots of time, today time is money.
3. Lime cement does not harden in water but stays soft. So there are situations where it cannot be used.

Uses and precautions

1. Lime concrete is very widely used for foundation bases of load bearing walls, columns, and under layers of floors.
2. Due to its flexibility it adjusts very well with the underneath base ground and upper construction of cement base.
3. For better quality of lime concrete it is important to compact & cure concrete properly. Lime causes rashes on human skin so the persons which are dealing lime concrete should be provided with suitable rubber gloves.
4. Persons should use oil on their skin to avoid rashes and cracking of their skin due to reaction of lime.
5. To achieve good quality lime concrete, certain admixtures, fibres etc. can be used.

LIME CONCRETE IN ROOF TERRACING

Materials:-All materials shall be of standard specifications. Coarse aggregate shall be of well burnt or over burnt brick ballast of 25mm gauge. It shall be deep cherry red or copper colour and shall be clean, free from dust ,dirt and other foreign matters. It shall be homogeneous in texture and roughly cubical in shape.

Fine aggregate shall be of surkhi, clean free from dust, dirt and foreign matters. Surkhi shall be made from well burnt bricks or brick bats(not over burnt)and shall pass through a screen of 25 meshes per sq cm(144 meshes per sq in).

Proportion:-Concrete shall consist of 1cu m brick ballast,0.36cu m of surkhi and 0.18cu m white lime(proportion 100:36:18 by volume).

Mixing:- It shall be similar to lime concrete in foundation.

Under

Laying and consolidation:-

Surface shall be lightly sprinkled with water and then concrete shall be laid slowly and gently (nay thrown) in layers so as to have the required slope and specified thickness after compaction.

The concrete shall then be lightly rammed with 6kg (12lbs) rammers and during preliminary ramming the surface shall then be perfectly levelled by means of trowel, straight edge and spirit level.

The concrete shall then be kept future consolidated by 2 rows of labourers sitting close and beating the concrete with wo

Olden 'thapis' and moving forward and backward covering the whole surface.

The beating shall continue for at least 7days until the concrete is thoroughly compacted and until the 'thapis' rebound from the surface when struck on the concrete.

Special care shall be taken to consolidated to concrete properly with the at junction with the parapet wall and the junctions shall be rounded. When beating is in progress, the surface of the concrete shall be frequently sprinkled with a mixture of lime molasses and boil solution of 'bale' fruit for water proofing. Bale fruit solution shall be prepared by boiling 2kg of bale fruit in 100 to 130 liters of water and to this solution after cooling 3.5kg molasses(gur)and the required quantity of lime shall be mixed.

Measurement-The measurement shall be taken for the finished work of superficial area in sq m (sq.ft) starting the average thickness. The average thickness shall be measured correct to 6mm and length and breadth shall be measured correct to 1cm.No deduction in measurement shall be made for opening up to 0.4 sq m and extra payment shall not be made for extra material or labour involved in forming such opening.

Instead of Bale fruit the solution of Terminally Chebula (kadukai) may be used, as used in south India. Dry nuts of kadukai shall be broken to small pieces, and allowed to soak in water. The solution be prepared to have a proportion of 600g of kadukai,200g of molasses and 40lits of water for 100sq m are of roof concrete. The solution is brewed for 12 to 24 hours, and the resulting liquor is decanted and used for the work.

NOTE-

1. If kankar lime is used,0.45 cu m of kankar lime shall be mixed with 1cu m brick ballast(proportion 45:100)
2. If stone ballast is used the proportion shall be 1cu m of stone ballast of 25 mm

Under

gauge ,0.5cu m of sand and 0.25cu m of white lime(proportion 1:2:3).

3. The finished thickness of lime concrete in roof terracing may be 7.5cm to 12cm (3"to 4.5")

4. The surface finishing may be taken in sq m under a separate item.

Detailed specification of cement concrete 1:2:4

Material:-

- Aggregate shall be of inert material & should be clean, dense, hard, sound, durable, non-absorbent & capable of developing good bond with mortar.
- coarse aggregate shall be of hard broken stone of granite or similar stone, free from dust, dirt & other foreign matters. The stone ballast should be of 20mm(3/4")size & down & all should be retained in a 5mm square mesh(1/4" square) & well graded such that the voids do not exceed 42%.(The gauge of stone ballast shall be as specified depending on the thickness of concrete & nature of work. For building work 20mm gauge & for road work & mass work 40 to 60mm gauge may be used.
- Fine aggregate shall be of coarse sand consisting of hard, sharp & angular grains & shall pass through screen of 5mm(3/16") square mesh. Sand shall be of standard specifications clean & free from dust, dirt,& organic matters. Sea sand shall not be used.(Fine aggregate may also be of cursed stone if specified).
- Cement shall be fresh port-land cement of standard I.S.I. specifications, & shall have the required tensile & compressive stresses & fineness.
- Water shall be clean & free form alkaline & acid matters & suitable for drinking purposes.

Proportion:-

- The proportion of concrete shall be 1:2:4 as cement: sand: stone: ballast by volume unless otherwise specified. Minimum compressive strength of c0ncrete of 1:2:4 proportion shall be 140kg per sq cm (20001bs/sq in)on 7days.
- Stone aggregate & sand shall be measured by volume with boxes. Cement need not be measured by box; one bag of cement (50kg) should be considered as 1/30 cu m (1.2 cu ft). Size of measured box may be 30cm*30cm*38cm or 35cm*28cm equivalent to content of one bag of cement. All material shall be dry. If damp sand is used compensation shall be made by

Under

adding additional sand to the extent required for the bulking of damp sand. Mixing shall be of machine mixing. For small work hand mixing by batches may be allowed.

Hand mixing:-

- Mixing shall be done in masonry platform or sheet iron tray. For concrete of 1:2:4 proportion, first two boxes of sand & one bag of cement shall be mixed dry thoroughly & then this dry mix of cement & sand shall be placed over a stack of 4 boxes of stone aggregate & the whole mixed dry turning at least three times to have uniform mix. Water shall then be added slowly & gradually with a water-can while
- being mixed to the required quantity 25 to 30 liters (5 to 6 gallons) per bag of cement, to give a plastic mix of the required workability & water cement ratio. The whole shall be mixed thoroughly turning at least three times to give a uniform concrete.

Machine mixing:-

- Stone ballast sand & cement shall be put in to the cement concrete mixer to have the required proportion. For concrete of 1:2:4 proportion first four boxes of stone ballast, then two boxes of sand & then one bag of cement shall be put in to the C.C. Mixer, the machine shall then be resolved to mix materials dry & then water shall be added gradually to the required quantity, 25 to 30 liters (5 to 6 gallons) per bag of cement to have the required water cement ratio. The mixing should be thorough to have a plastic mix of uniform color. It requires 1 ½ to 2 minutes rotation for thorough mixing. Mixed concrete shall be unloaded on a masonry platform or on a sheet iron. Output of concrete mixer is 15 to 20 mix per hour.

Slump:-

- Regular slump test should be carried out to control the addition of water & to maintain the required consistency. A slump of 7.5cm to 10cm (3" to 4") may be allowed for building work, & 4cm to 3cm (1 ½" to 2") may be allowed for road work.

Formwork:-

- Formwork centering & shuttering shall be provide as required, as per standard specification before lying of concrete in position. The inner surface of shuttering shall be oiled to prevent concrete sticking to it. The base & formwork over which concrete to be laid shall be watered by sprinkling water before concrete is laid. Forms should not be removed before 14 days in general, side forms may however be removed after 3 days of concreting. Formworks shall be removed slowly & carefully without disturbing & damaging concrete.

Under

Laying:-

- Concrete shall be laid gently(not thrown)in layers not 15cm(6") & compacted by pining with rods & tamping with wooden tampers or with mechanical vibrating machine until a dense concrete is developed.(for important work mechanical vibrating should be used, for thick or mass concrete immersion type vibrators & for thin concrete surface vibrators should be used for compacting concrete).Over-vibration which is will separate coarse aggregate from concrete should be used be avoided. After removal of the formwork in due time the concrete surface shall be free form honey combing, air holes or any other defect.
- concrete shall be laid continuously, if laying is suspended for rest or for the following day the end shall be sloped at an angle of 30 degree & made rough for further jointing. When the work is resumed, the previous sloped portion shall be roughened. Cleaned & watered & group of neat cement shall be applied & the fresh concrete shall be laid. For successive layer shall be laid before the lower has set.

Curing:-

- After about two hours laying when concrete has begun to harden, it shall be kept damp by covering with wet gunny bags or wet sand for 24 hours, and then cured by flooding with water making mud walls 7.5cm high or by covering with wet sand or earth & kept dam continuously for 15 days. If specified, curing may be done by covering concrete with special type of waterpr0of paper as to peasant water escaping or evaporation.

DETAILED SPECIFICATION of REINFORCED CEMENT CONCRETE

REINFORCED CEMENT CONCRETE (R.C.C)-

❖ STEEL-

- Steel reinforcing bars shall be of mild steel or deformed steel of standard specifications and shall be free from corrosion, loose rust scale, oil, grease, paint, etc.
- The steel bar shall be round and capable for being bent (doubled over) without fracture. Bars shall be hooked and bent accurately and placed in position as per design and drawing and bound together tight with 20 S.W.G annealed steel wire at their point of intersection.
- Bars shall be bent cold by applying gradual and even motion, bars of 40 mm(1 ½") diameter and above may be bent by heating to dull red and allow to cool slowly without immersing in water. Joints in the bars should be avoided as far as possible, when joints have to be made an overlap of 40 times diameters of

Under

the bar shall be given proper hooks at ends and joint should be staggered.

-
- Bars shall be bent cold by applying gradual and even motion, bars of 40 mm (1 ½") diameter and above may be bent by heating to dull red and allow to cool slowly without immersing in water. Joints in the bars should be avoided as far as possible, when joints have to be made an overlap of 40 times diameters of the bar shall be given proper hooks at ends and joint should be staggered.
- Bigger diameter bars should be joined by welding and tested before placing in position. While concreting steel bar shall be given side and bottom covers of concrete by placing precast concrete blocks underneath of 1:2 of cement mortar 2.5 cm*2.5cm(1"*1") in section and thickness of specified covers, 4 cm to 5 cm (1 ½" to 2") for beam and 1 cm to 2 cm (½" to ¾") for slab.
- During laying and compacting of concrete the reinforcing bars should not move from their positions and bars of the laid portions should not be disturbed.

❖ **CENTERING AND SHUTTERING-**

Centering and shuttering shall be made with timber or steel plate close and tight to prevent to leakage or mortar, with necessary props, bracing and wedges, sufficiently strong and stable and should not yield on laying concrete and made in such a way that they can be slackened and remove gradually without disturbing the concrete.

- No plastering should be made on concrete surface. A coat of oil washing should be applied over the shuttering or paper should be spread to have a smooth and finished surface to prevent adherence of concrete.
- For slab and beam small chamber should be given in centring, 1 cm per 2.5 cm (1/2" per 10 ft.) with a maximum of 4 cm (1 ½"). Centring and shuttering should not be removed before 14 days in general (4 days for R.C.C. columns, 10 days for roof slab , and 14 days for beam).The centring and shuttering shall be removed slowly and carefully so that no part is disturbed or damaged.

❖ **PROPORTION OF CEMENT CONCRTE-**

Cement concrete shall be of 1:2:4 proportions by volume for slabs, beams and lintels, and 1:1 ½:3 proportion for columns unless otherwise specified.

❖ **MATERIALS FOR CONCRETE-**

- Coarse aggregate shall be of hard broken stone of granite or similar stone, free from dust, dirt and other foreign matters. The stone ballast shall be of 20

Under

m (3/4") size and down all should be retained in a 5 mm square mesh (1/4" square) and well graded such that the voids don't exceed 42 per cent.

- Fine aggregate shall be coarse and consisting of hard, sharp and angular grains and shall pass through screen of 5 mm (3/16") square mesh. Sand shall be of standard specification clean and free from dust, dirt, and organic matters. Sea sand shall not be used.
- Cement shall be fresh Portland cement of standard I.S.I. specification, and shall have the required tensile and compressive stresses and fineness.
- The stone aggregate shall usually be 20 mm to 6 mm (3/4" to 1/4") gauge unless otherwise specified. For heavily reinforced concrete member as in the case of ribs of main beams the maximum size of aggregate should usually be restricted to 5 mm less than the minimum cover to the reinforcement whichever is smaller. Where the reinforcement is widely spaced, limitations of the size of the aggregate may not be so important.

❖ **MIXING-**

❖ **HAND MIXING-**

- Mixing shall be done in masonry platform or sheet iron tray. For concrete of 1:2:4 proportion, first two boxes of sand and one bag of cement shall be mixed dry thoroughly and then this dry mix of cement and sand shall be placed over a stack of 4 boxes of stone aggregate and the whole mixed dry turning at least three times to have uniform mix. Water shall then be added slowly and gradually with water-cannon while being mixed to the required quantity 25 to 30 liters (5 to 6 gallons) per bag of cement, to give a plastic mix of the required workability and water cement ratio. The whole shall be mixed thoroughly turning at least three times to give a uniform concrete.

❖ **MACHINE MIXING-**

- Stone ballast sand and cement shall be put into the concrete mixer to have the required proportion. For concrete of 1:2:4 proportion first four boxes of stone ballast, then two boxes of sand and then bag of cement shall be put into the C.C. mixer, the machine shall then be revolved to mix materials dry and then water shall be added gradually to the required quantity, 25 to 30 liters (5 to 6 gallons) per bag of cement to

have the required water cement ratio. The mixing should be through to have a plastic mix of uniform colour. It requires 1 1/2 to 2 minutes rotation for thorough mixing. Mixed concrete shall be unloaded on a masonry platform on a sheet iron. Output of concrete mixer is 15 to 20 cubic meters per hour

❖ **LAYING-**

- Before laying the concrete, the shuttering shall be clean, free from dust, dirt and other foreign matters. The concrete shall be deposited (not dropped) in its final position. In case of columns and walls it is desirable to place concrete in full height if practical so as to avoid construction joints but the progress of

concreting in the vertical direction shall be restricted to one meter per hour.

- Care should be taken that the time between mixing and placing of concrete shall not exceed 20 minutes so that the initial setting process is not interfered with. During winters concreting shall not be done if the temperature falls below 4° C . Concrete shall be protected by frost and concrete affected by frost shall be removed and work redone.
- Concrete shall be compacted by mechanical vibrating machine until a dense concrete is obtained. The vibration shall continue during the entire period of placing concrete. Compaction shall be completed before the initial setting starts, i.e., within in 30 minutes of addition of waters to the dry mixture.
- Over vibration which will separate coarse aggregate from concrete shall be avoided. After removal of the form work in due time, the concrete surface shall be free from honey combing, Air holes or any other defect.
- Concrete shall be laid continuously, if laying is suspended for rest or the following day, the end shall be sloped at an angle 30° and made rough for future jointing. When the work is resumed, the previous sloped position shall be roughened, cleaned and watered and a coat of neat cement shall be applied and the fresh concrete shall be laid.
- For successive layer the upper layer shall be laid before the lower layer has set.
- Structures exceeding 45 meters in length shall be divided by one or more expansion joints. Structures in which plan dimension changes abruptly shall be provided with expansion joints at the section where such changes occur.
- Reinforcement shall not extend across an expansion joint at the break between the section shall be complete.

❖ CURING-

- After about two hours' laying when concrete has begun to harden, it shall be kept damp by covering with wet gunny bags or wet sand for 24 hours, and then cured by flooding with water making mud walls 7.5 cm(3") high or by covering with wet sand or earth and kept damp continuously for 15 days. If specified, curing may be done by covering concrete with special type of waterproof paper as to prevent water escaping or evaporating.

❖ FINISHING-

If specified the exposed surface shall be plastered with 1:3 cement sand mortar not exceeding 6 mm(1/4") thickness and the plastering shall be applied immediately after removal of the centring while the concrete is green. Immediately before applying the plaster the surface of concrete shall be wetted and neat cement wash shall be given.

❖ MEASUREMENT-

Under

- Measurement shall be taken in cu m (cu ft.) for the finished work and no deduction shall be made for the volume of steel. Steel reinforcement shall be measured under a separate item in quintal (cwt.). Plastering, if any, shall be included in the measurement. The rate for R.C.C. work shall be for the complete work excluding steel but including centring and shuttering and all tools and plants.

DETAILED SPECIFICATION OF DAMP PROOF COURSE

Dampness in Buildings

Protect building and people from harmful effects caused by

- Ground moisture
- Rain
- Interstitial and surface condensation
- Spillage of water from sanitary objects

What is Dampness?

Damp is generally defined as unwanted water or moisture.

The existence of dampness in buildings is one of the most damaging failures that can occur in buildings.

It can cause

- Damage in brickwork by saturating it
- Decay and breaking up of mortar joints
- Dry and wet rot in timber structures
- Corrosion of iron and steel

Physical Effects

- Freeze/thaw
- Timber rot
- Water staining
- Cyclic wetting/drying
- Insulation values reduced
- Electrics made unsafe

Under

Chemical effects

Efflorescence

Crypto florescence

Corrosion of ferrous metals

Chemical attack (e.g. sulphate)

Cohesion loss

Effects on Health

- Ambient air conditions
- Mould growth & spores
- Viruses & infections
- Rot & infestation
- Psychological

Rising Damp

The majority of construction materials are porous.

This means they will soak up a considerable amount of water.

Rising Damp

Rising damp **is caused by a natural phenomenon called 'capillary action'** wherein ground water is drawn vertically upwards through fine pores in a material.

Construction materials are either embedded in, or in contact with the ground which will encourage the migration of water from the ground by capillary action.

Furthermore, osmosis encourages the movement of water relative to the concentration of salts.

Causes

The occurrence of rising damp is generally associated with older properties of traditional construction.

Causes

Other potential causes of rising damp include:

Under

1. By-passing of the DPC caused by bridging internally by a porous floor screed
2. By-passing of the DPC externally by raised paths, planting borders etc
3. By-passing of the DPC with external render coating
4. Rain splashing on the external ground and passing above the DPC level
5. Build-up of debris in a cavity allowing by-passing of the DPC
6. Failure to link the DPC with the impervious (watertight) membrane or damp proof membrane (DPM) in adjacent solid floors.

Effect

Stained decoration

Rusting to skirting nails

Decay to timber skirting

Breakdown of plasterwork

Effect

The presence of dampness is visible as a tidal pattern on the wall and can be measured by a moisture meter.

For rising damp moisture content will be high at low level, and diminishing quickly up the wall.

Remedial DPCs

The purpose of remedial DPCs is to attempt to arrest the passage of moisture from the ground through the walls by inhibiting the natural process of capillary action. One can categorise the most common forms of remedial DPCs into

- Chemical DPCs
- Physical DPCs

Chemical DPCs

This technique uses liquid which is either introduced into the wall by simple gravity or under pressure.

This liquid will either fill the pores of a material with water resistant material (pore fillers) or line them with a non-wet-table surface to reduce capillary attraction (pore liners).

Thus a damp proof course will be created.

Under

Physical DPCs

Are layers of impervious material which is inserted into a carefully cut gap.

Pieces have to overlap to make sure they are tight.

Penetrating Damp

The occurrence of penetrating damp is highly dependent upon the levels of exposure of the building and it is often the case that moisture penetration occurs only on certain areas or elevations of the building.

In traditional construction high levels of exposure force moisture through a wall.

In more modern buildings penetrating dampness is often associated with failures of joints and seals.

Cracks caused by other defects can also be a cause.

Penetrating Damp

Ingress of rainfall

Erosion of the façade surface material Propulsion of the water through openings

Penetrating Damp

Dampness in Buildings

Some of it will be immobilised by the hydration process of mortar and cement.

However, much of the water will remain and one cannot do much about it but it will dry out very slowly, so good ventilation and low heating during the first months will assist the drying process.

It may take a considerable period of time before all of the construction moisture is removed from the building fabric.

Remedial actions

It is important to determine the source of water/moisture ingress before taking any remedial damp proofing action.

As just seen there may be one or more sources, such as penetrating damp, plumbing defects, condensation, bridging of the DPC, or absence of effective damp proofing resulting in dampness.

Details specification of brickwork 1st class

Bricks -- All bricks shall be of 1st. class of standard specification made of good brick

Under

earth thoroughly burnt, and shall be of deep cherry red or copper colour bricks shall be regular in shape and their edges should be sharp and shall emit clear ringing sound on being struck and for shall be free from cracks, chips, flaws, and lumps of any kind.

Mortar-mortar shall be specified and materials of mortar shall be of standard specification. For cement mortar cement shall be fresh Portland cement of standard specification. Sand shall be sharp, clean and free from organic and foreign matters for rich mortar coarse or medium cement should be used and weak mortar local fine sand may be used. Proportion of cement sand mortar may be of (1:3 to 1:6 as specified) materials of mortar shall be measured to have the required proportion with measuring box. Lime surkhi (or sand or cinder)mortar if specified shall be mixed in the specified proportion by grinding in mortar mill at least three hrs. on the same day of use. Lime shall be fresh and slaked and screened at site of work.

Soaking of bricks-bricks shall be fully soaked in clean water by submerging in a tank for a period of 12 hrs immediately before used. Soaking shall be continued till air bubbling is ceased.

Laying-bricks shall be well bonded and laid in English bond unless otherwise specified. Every course shall be truly horizontal and shall be truly in plumb. Vertical joints of consecutive course shall not come directly over one another; vertical joints in alternate course shall come directly over one another. broken bricks shall not be used mortar joints shall not exceed 6mm. in thickness and joints shall be fully filled with mortar. where frogs shall be placed down-ward at an angle of 45 degree.

Curing point-the brick work shall be caped wet for a period of at least 10 days after laying. At the end of days works. The tops of wall shall be flooded with water by making small weak mortar edging to contain at least 2.5cm. Deepwater.

Protection-the brick work shall be protected from the effect sun, rain, frost etc. during the construction and until such time it is green and likely to be damaged.

Scaffolding-necessary and suitable scaffolding be provided to facilitate the construction of the brick wall. Scaffolding shall be sound and strong and support and member sufficiently strong so as to withstand all loads likely to come upon them.

Measurement-brick work shall be measured in cu m.(cu ft.).Different kind of brick work with different mortar shall be taken under separate items. The thickness of wall shall be taken as multiple of half brick as half brick 10cm.,1 brick 10cm,1 brick 20cm,1.5 brick 30cm,so on.

Brick work arch-in addition to the above type of arch-rough case arch or axed or gauged arch as the case may be, and the centring of the arch should be specified.

Under

Detailed specification of brickwork 2nd & 3rd class, Brickwork in mud mortar pointing (cements or lime mortar).

Brickwork II class and III class

For II class brickwork bricks shall be of second class and mortar shall be as specified, may be kankar lime or white lime and surkhi (or sand) of 1:2 to 1:3 proportion. Mortar joints shall not exceed 10mm (3/2") in thickness. Bricks shall be soaked in water for at least three hours immediately before use. Other details are same as for item 7 above.

For III-class brickwork brick shall be III class if otherwise not specified. Mortar shall be as specified and mortar joints shall not exceed 12mm (3/4") in thickness. Bricks shall be dipped into a tub of water before use.

Pointing (cement or lime mortar)-

The joints of the brickwork shall be raked out to a depth of 20mm (3/4") and the surface of the wall washed and cleaned and kept wet for two days before pointing.

The materials of mortar cement and sand, or lime and surkhi or sand, or kankar lime as specified, shall be of standard specification. The materials of mortar shall be first dry mixed by measuring with boxes to have the required proportion as specified (1:2 or 1:3 for cement sand mortar, 1:1 for lime surkhi mortar or kankar lime mortar), and then mixed by adding water slowly and gradually and thoroughly mixed.

Mortar shall then be applied in the joints slightly in excess and pressed by a proper tool of the required shape. Extra mortar if any is removed and surface finished. Mortar shall not spread over the face of bricks, and the edges of the bricks shall be clearly defined to give a neat appearance. After pointing the surface shall be kept wet for seven days.

Flush pointing- The mortar shall be pressed into the raked, cleaned and wet joints and shall be finished off flush and level with edges of brick to give a smooth appearance. The edges shall be neatly trimmed with a trowel and straight edge.

Ruled pointing- The mortar shall be passed into the raked, cleaned and wet joints and a groove of shape and size of 5 to 6mm deep shall be formed running a forming tool of steel along the center line of the joints. The vertical joints also shall be finished in a similar way at right angles to the horizontal line. The finished work shall give a neat and clean appearance with straight edges.

Weather or truck pointing- The mortar shall be applied on the cleaned and wet joints and horizontal joints shall be pressed and finished with a pointing tool so that the joints is sloping from top to bottom. The vertical joint shall be finished as ruled pointing.

Raised or Trucked pointing- The mortar shall be applied in raked, cleaned and wet

Under

joints in excess to from raised bands. The mortar shall be pressed and run with proper tool to from bands of 6mm(1/4") raised and 10mm (3/8") width or as directed.

Detailed specification of rain force bricks work.

Brick work 2nd class&3rd class-

For second class brick work brick shall be of second class and mortar shall be as specified. may be kankar line or white line and surkhi of 1:2to1:3 proportion. mortar joints shall not exceed 10mm(3/4")in thickness .bricks shall be soaked in water for at least three hour immediately before use. Other details are same as for item 7 above.

For third class brick work bricks shall be third class if otherwise not specified. Mortar shall be as specified and mortar joint shall not exceed 12mm in thickness. Bricks shall be dipped into a tub of water before use.

Brick in mud mortar-

Bricks shall be specified may be 2nd class & 3rd class. The mud should be made of selected earth of tenacious so that it sticks and binds bricks. The earth should be soaked in water at least one day before and then worked up with water by labourer treading it, until it is perfectly free of bricks isn't require. other details of laying protection scaffolding and measurement will be similar to item 7 above.

Reinforced brick work (R.B. work)-

Material-Bricks shall be strictly of first class quality and selected first class bricks shall be used. mortar shall be consist of cement & coarse sand of 1:3 proportion. Cement shall be fresh pot-land cement. sand shall be coarse of 5mm (3/16")size & down and sharp clean and free from foreign matters.

Centring and shuttering-

The centring and shuttering shall be made with planking or shitting of bamboos packed together at the required level supported on runners of beams and covered with a thin layer of about 2.5cm thick of earth finished of with a light sprinkle of sand. The centring shall be simple in construction so that it could be easily removing without disturbing the structure. The planking shall be kept clear of the bearing for slab and will rest on cross beams only planks shall not be led too close as to tender them liable to jam. The top surface of centring shall be given a camber of 2mm for every 30cm of span up to a maximum of 3mm of slab and1.5mm for every 30cm of span to maximum of span to maximum of 4cm for lintels.

Mixing of Mortar-

Mortar of cement and sand shall be mixed in the proportion of 1:3 first by mixing dry

Under

and then adding water slowly and gradually and mixing by turning at-least 3 times to get uniform plastic mix of consistency so that the mortar tagged round the rain force-domain shall never be used.

Laying-

All bricks shall be thoroughly shocked with water for not less than 6hours immediately before used. Bricks shall be led with frogs downward over the centring in straight line paralal to the direction of reinforcement bars leaving the required gap for mortar changed. reinforcement has to be placed shall not be less than 4times the diameter of the bar so as to provide a cover of 12mm (1/2")on all sides of the still bar. other joint where than will not be any bar may be 6mm to 10mm thick.

After the bricks have been led and arranged over the hole area fresher mixed mortar shall be placed in to the gaps in between the bricks to a thickness of 2.5mm (1")reinforcing rods previously cut to the correct Len and bend and hocked as per design shall be placed exactly at the centre of the joint and perished down into the mortar to leave 12mm.Newly led portion shall not be disturbed at all points is completely surrounded on all sides by mortar.

Centring and shuttering shall be removed slowly and carefully without any shock not earlier than 10 days. after removal of centring if the work is found defective and rods are expose and visible to sufficient extend the work shall be dismantled and reconstructed. In such a case no extra payment shall be made for reconstruction they should be covered with reach cement mortar.

For double layers the upper layer shall be led with joints of 10mm(3/8")thickness with 1:3 cement and coarse sand mortar immediately the bottom layer if there are top bars provided in the upper layer the joint shall be thicker as per bottom layer.

cm to 4cm (1"to1")thick cement concert of 1:2:4 proportion may be provided over the one layer of R.B.work if specified to have a greater compressive strength.

Finishing-

Plastering of underside and side shall be done immediately after opening of the centring with fresh cement and courses and mortar of 1:3 proportion to a minimum thickness of 12mm(1/2").Before plastering the surface shall be given a work of need cement with water.

SPECIFICATION OF PLASTERING CEMENT MORTAR OR LIME MORTAR

INTRODUCTION

- Plastering is the process of cone rough surface of walls, columns, ceilings and other building components with thin coat of plastic mortars to form a smooth durable surface.
- The coating of plastic material (i.e. mortar) is termed as plaster.

Under

- Plastering on external exposed surfaces is known as rendering.
- The joints of the brickwork shall be raked out to a depth of 18 mm and the surfaces of the wall shall be washed and kept wet for two days before plastering.

MATERIALS

- The materials of mortar, cement and sand or lime and surkhi or sand, or kankar lime, as specified should be of standard specifications.
- The materials or mortar shall be first dry mixed, by measuring with boxes to have the required proportion.
- Then water added slowly and gradually and mixed thoroughly.

THICKNESS

- The thickness of plastering shall be usually 12 mm applied in two or three coats.
- To ensure uniform thickness of plaster, patches of 15 mm * 15 mm(6") strips, 1m (3') apart or 10 cm(4")wide shall be applied first at about 2m(6') apart to act as a guide.
- First mortar shall be dashed and pressed over the surface and then brought to a true smooth and uniform surface by means of float and trowel.

TYPES

- **External plastering** shall be started from top and worked down towards floor.
- **Internal plastering** shall be started wherever the building frame is ready and centering of the roofs slabs have been removed.
- **Ceiling plastering** shall be completed before starting of wall plaster.

COATINGS

- **The first coat** is of 10mm. The first coat shall be applied on the prepared raked cleaned and wetted surface by dashing the mortar.
- **The second coat** is of 10 to 6mm. When the first coat has set, the second coat of plaster shall be applied and brought to true even surface and then lightly roughened with a wooden float to provide bond for finishing coat.
- **Finishing coat** is of 5 to 6mm. The finishing coat shall be applied on the wetted surface of the second coat and finished smooth to true even surface by float and trowel.

TESTING

Under

- The work shall be tested frequently with a straight edge and plumb bob.
- At the end of the day the plaster shall be cut clean to line.
- When the next day's plastering is started and edge of the old work shall be scrapped, cleaned and wetted with cement slurry.
- At the end of the day the plastering shall be closed on the body of the wall and not nearer than 15cm to any corner.

PRECAUTIONS

- Curing shall be started as soon as the plaster has hardened sufficiently not to be damaged when watered.
- The plaster shall be kept wet for at least 10 days.
- Any defective plaster shall be cut in rectangular shape and replaced.

PROPORTIONS OF MORTAR

- Cement sand mortar---- 1:3, 1:4, 1:5, 1:6
- Cement, lime, sand mortar---- 1:1:6 ; C:L:S
- Lime surkhi or sand mortar ----1:1, 1:2
- Kankar lime mortar---- kankar lime alone
- For ceiling plastering 1:3 cement mortar with coarse sand is generally used.
- **Detailed Specification of 2.5 cm cement concrete floor**
- **2.5cm (1") cement concrete floor**
 - The cement concrete shall be of proportion 1:2:4 or 1:2¹/₂:3:1¹/₂ as specified. Cement shall be fresh Portland cement of standard specification. The coarse aggregate shall be hard and tough (granite stone) of 20mm (3/4") gauge, well graded and free from dust, dirt, etc. The sand shall be coarse of 5mm (3/16") maximum size and down, well graded, clean and free from dust, dirt and organic matters.
 - The floors shall be levelled and divided into panels of size not exceeding 1 metre in its smaller dimensions and 2 metres in large dimensions. Glass or aluminium strips 3mm thick and depth equal to thickness of floor shall be fixed on the base with cement mortar. Required camber of slope shall be given in the floor for draining wash water.
 - Mixing of concrete shall be done either by hand mixing or by mechanical mixer. In case of hand mixing first cement and sand mixed thoroughly and the dry mix of cement and sand mixed with ballast dry till stone ballast are well coated with dry mix of cement and sand and then mixed by adding water

Under

slowly and gradually to the required quantity and mixed thoroughly to have uniform plastic mix. The quantity of water must not exceed 30litres per bag of cement. Concrete for one panel only shall be mixed in one lot. Alternate panels shall be laid on alternate days. The floor shall be laid in two layers. The lower layer being 25 mm thick and upper layer 3 mm thick. The base shall be made rough and cleaned and soaked with water thoroughly and then given a cement wash just before laying. Concrete shall be placed gently and evenly and compacted by beating with wooden 'thapies' and then the surface shall be tamped with the wooden tampers. The surface shall then be smoothed with wooden floats

and any unevenness shall be removed by adding 1:2 cement sand mortar. The whole operation of laying shall be completed within 30 minutes. After laying the surface shall be laying undisturbed for 2 hours and then covered with wet bags and after 24 hours cured by flooding with water and kept flooded for at least 7 days. The surface of floor may be polished if specified. It is important that same brand of cement should be used for the whole floor of one room and the proportions are maintained strictly to have a uniform colour. Junctions of floor with wall plaster, dado and skirting shall be rounded off neatly.

- **Coloured floor-** For coloured finish the surface shall be finished with coloured cement or with a mixture of ordinary Portland cement and coloured pigment of the desired colour in the proportion of 3 of cement and one of colour (or 4:1 or 5:1). For coloured floor the thickness of the two layers shall be 19 mm and 6 mm. For polished floor the thickness of the surface cement finishing should be 2.5 mm to allow for grinding and polishing.
- **Base-** In ground floor c.c. floor is to be laid on a 7.5 cm (3") base of lime concrete or weak cement concrete as per standard specifications. If the bases consists of cement concrete it shall be allowed to set for about 7days. In case the base is of weak cement concrete the flooring shall commence within 48 hours of laying the base.
- In first floor or upper floor if c.c. floor is to be laid on RCC slab. The surface of RCC slab shall be made rough with brushes while concrete is green. Before laying the c.c. floor the surface shall be cleaned, wetted and a neat cement wash shall be applied to get a good bond. A base of lime concrete may also be provided over the RCC slab if specified. The base shall be provided with the slope required for the flooring.
- The thickness of c.c. floor for office building, school building, and in upper floor should be 4 cm (1.5").

White washing -

Fresh white lime slacked at site of work should be mixed with sufficient water to make a thin cream. The approximate quantity of water required in making the cream is 5 liters of water to 1 kg of lime. It shall then be screened through a coarse cloth and gum (glue)

Under

in the proportion of 100 grams of gum to 16litres (three chat tacks of gum to 6 gallons) of wash shall be added .the surface should be dry and thoroughly cleaned from dust and dirt. The wash shall be applied with 'moon' or jute brush, vertically and horizontally alternately and the wash kept stirred in the container while using. Two or three coats shall be applied as specified and each coat shall be perfectly dry before the succeeding coat is applied over it. After finishing the surface shall be of uniform colour. The white wash should not splash on the floor and other surfaces. In old surface the surface should be cleaned and repaired with cement mortar where necessary and allowed to dry before white wash is applied . For final coat blue pigment powder should be mixed to the required quantity with the lime water to give a bright white surface.

Colour washing -

Colour wash shall be prepared with fresh slaked white lime mixed with water to make thin cream adding the coloured pigment to the required quantity to give the required tint. Gum (glue)in the proportion of 100 gm of gum to 16 litres (three chat tacks of gum to six gallons)of wash shall be added. The colour wash may be applied one or two coats as specified. The method of application should be same as for white washing(item 17). For new work the priming coat shall be of white wash.

Distempering-

The distemper shall be of best quality and the colour should be as specified. The distemper should be mixed and prepared and water added, as laid down in the instructions of the manufacturer. First a paste is made by adding little hot water to the distemper powder and stirred thoroughly, and the paste is allowed to stand for a few minutes. The paste is then thinned with water to have a thin cream to the consistency of oil paint and stirred thoroughly all the time while applying. If the surface is rough, it should be smoothed with sand paper.

The surface must be perfectly dry before distempering is commenced. In new cement plaster the surface shall be washed over with a solution of zinc sulphate , one kg zinc sulphate ,one kg zinc sulphate in 10 litres of water and then allowed to dry .in old surface , the surface shall be repaired with plaster of Paris where required and then whole surface sand papered and washed and allowed to dry.

The number of coats shall be two or as specified. The distemper shall be kept well stirred in containers and shall be applied with broad brushes first horizontally and immediately crossed vertically. Brushing should not be continued too long to avoid brush marks. The second coat shall be applied after the first coat is dried up. After each day's work the brushes shall be washed and kept dry .distempering should be done during dry weather but not during too hot weather, nor wet weather.

Oil distemper- oil distemper is similar to ordinary dry distemper in powder form .in the oil distemper compound (dry powder) oil is mixed by the manufacturer while manufacturing. For application of oil distemper it is mixed with the required quantity of

Under

water and then applied on the surface .the methods of preparation and application are similar as described above.

Snowmen washing-

General- Snowmen consists of a base of white cement mixed with finely powdered colouring pigment to have the desired colour and with the addition of small quantities of other ingredients. it gives a water proof surface. Snowmen is sold by the manufacturer in 50 kg drums, 25kg drums and 5kg tin of various colours. The snowed of the desired colour may be chosen.

Mixing- only fresh snowmen should be used. Hard or set snowcem should not be used. The contents should be made loose by rolling and shaking the container before opening the container. First a paste shall be prepared by mixing 2 parts of snowcem powder with one part of water by volume and immediately this should be thinned by adding another one part of water to have a uniform solution of consistency of paints.

[Mix 1 litre (2 pints) of water with 3kg (7lbs) of snowcem powder to get a paste ,dilute this with another 1 litre (2 pints) of water which will give approximately 3 litres (6pints) of snowcem for application .]

Application-The surface should be cleaned to remove loose dust or dirt by use of a soft wire brush. The surface shall then be wetted by sprinkling with water and shall be allowed to run off. The fresh mixed snowcem shall then be applied with broad good quality brush. The first coat shall be well brushed into the surface to form a good bond. Snowcem should be used within an hour of mixing and should be kept stirred during application. At the end of the day each application of snowcem the surface should be wetted with fine water spray for curing.

After a day or two a second coat of snowcem of similar preparation should be applied on the wetted surface and the second coat should be applied carefully to give a uniform and good finished appearance.

The approximate covering capacity of 50 kg of snowcem for two coats on plastered surface is 100 sq m (1000 sq ft).

Other cement washing compound as supercem , Aquacem, Durocem, etc., may also be used similar to snowcem.

Decorative cement colour washing (similar to snowcem)-

For decorative as well as water repellent washing on the external surface of buildings, white cement mixed with colour (pigment) and other ingredients may be

Under

used. The quantities(proportion) of the different ingredients in percentage basis as well as per bag of cement are given below):-

Ingredients	percentage by weight	per bag of cement
(1)White cement	75%	50 kg
(2)Slaked lime (clean, screened)	10%	6.5 kg
(3)Powdered glue	10%	6.5 kg
(4)Alum	2%	1.3 kg
(5)Aluminium stearate	½%	0.33 kg
(6)Plaster of paris	2 ½%	1.63 kg

To get the desired colour and shade, powdered metallic colour should be mixed with white cement to the extent of 5% to 10% of the white cement by weight (2.5 kg to 5 kg per bag of cement)

Mixing and preparation- slaked lime should be dissolved in cold water and powdered glue and powdered alum should be dissolved in hot water in separate containers or drums. The solution should be thin and should be screened through a piece of cloth, and prepared and kept ready in advance of application.

At the time of application white cement, plaster of Paris aluminium stearate and colour should be mixed intimately in the above mentioned proportions and the mixture added to the slaked lime solution and stirred continuously. The alum and glue solutions should then be added and stirring continued. Fresh water should then be added to bring the solution to the consistency of a cream similar to oil paint. The final mixed solution should consist of all the ingredients in the proportion mentioned above. The mixing should be by batches of about ¼ bag of cement at a time with other ingredients in the same proportion. A uniform consistency should be maintained for all batches of mix. Only as much quantity as can be used within half an hour should be prepared and mixed at a time.

Application of wash- Before the wash is applied, the surface should be rubbed and cleaned of all loose dust and dirt, and washed with water and wetted. The mixed cement wash should then be applied evenly with broad distemper brushes. Second coat should be applied after 4 hours and during this period the surface should be kept moist.

Curing- after application of the cement the surface should be kept moist for at least two days by frequent light sprinkling of water. Surface should be protected from hot sun and drying winds by hanging hessian cloth on the scaffolding and periodically wetting it with water.

Under

Covering capacity-one bag of white cement (50kg) mixed with other ingredients will cover an area of 80 sq m to 100 sq m (800 sq ft to 1000 sq ft) for two coats over plastered surface.

One expert washer(white washer) and one boy coolie can wash 30 sq m to 40 sq m (300 sq ft to 400sq ft)per day for first coat, and 40 sq m to 50sq m(400 sq ft to 500 sq ft). per day for second coat.

painting-

The brand of the paint shall be specified and ready-made paint of the required colour should be used. If thinning is required, pure turpentine may be added to the required extent. The surface shall be made perfectly smooth by rubbing with sand paper of different grades, first with coarse one and successively with fine sand papers. All holes and open joints should be filled with strong putty or with a mixture of glue and plaster of Paris and smoothed by rubbing with sand paper. In steel work, all ruses and scales shall be perfectly removed by scrapping and brushing.

Calculation of dry materials & ANALYSIS OF RATES

Definition: In order to determine the rate of a particular item, the factors affecting the rate of that item are studied carefully and then finally a rate is decided for that item.

This process of determining the rates of an item is termed as analysis of rates or rate analysis. The rates of particular item of work depend on the following.

1. Specifications of works and material about their quality, proportion and constructional Operation method.
2. Quantity of materials and their costs.
3. Cost of labours and their wages.
4. Location of site of work and the distances from source and conveyance charges.
5. Overhead and establishment charges
6. Profit

Cost of materials at source and at site of construction.

The costs of materials are taken as delivered at site inclusive of the transport local taxes and other charges.

Purpose of Analysis of rates:

1. To work out the actual cost of per unit of the items.
2. To work out the economical use of materials and processes in completing the particulars item.
3. To work out the cost of extra items which are not provided in the contract Bond, but are to be done as per the directions of the department.
4. To revise the schedule of rates due to increase in the cost of material and Labour or due to change in technique.

Cost of labour -types of labour, standard schedule of rates

The labour can be classified in

Under

- to 1) Skilled 1st class
- 2) Skilled 2nd Class
- 3) un skilled

The labour charges can be obtained from the standard schedule of rates 30% of the skilled labour provided in the data may be taken as 1st class, remaining 70% as II class. The rates of materials for Government works are fixed by the superintendent Engineer for his circle every year and approved by the Board of Chief Engineers. These rates are incorporated in the standard schedule of rates.

Lead statement: The distance between the source of availability of material and construction site is known as "Lead " and is expressed in Km. The cost of conveyance of material depends on lead. This statement will give the total cost of materials per unit item. It includes first cost, conveyances loading, unloading stacking, charges etc.

The rate shown in the lead statements is for metalled road and includes loading and staking charges. The environment leads on the metalled roads are

Arrived by multiplying by a factor a)

for metal tracks - lead x 1.0

b) For cartze tracks - Lead x 1.1 c)

For Sandy tracks - lead x 1.4

Note: For 1 m³ wet concrete - 1.52 m³ dry concrete approximately SP. of concrete = 1449 kg/m³ (or) 1.44 t/m³, 1 bag of cement - 50 Kg

Example 1:- Calculate the Quantity of materials for the following items.

a) R.C.C. (1:2:4) for 20 m³ of work

b) R.C.C. (1:3:6) for 15 m³ of work

Quantity of cement required = $1.52 \times 20 = 30.4 \text{ m}^3 = 19.26 \text{ bags}$

Quantity of sand required = $\frac{2}{7} \times 1.52 \times 20 = 8.78 \text{ m}^3$

Quantity of coarse aggregate = $\frac{4}{7} \times 1.52 \times 20 = 16.57 \text{ m}^3$

b) Quantity of cement required = $1.52 \times 15 = 22.8 \text{ m}^3 = 14.28 \text{ bags}$

Quantity of sand required = $\frac{2}{5} \times 1.52 \times 15 = 4.56 \text{ m}^3$

Example 8:- Prepare a data sheet and calculate the cost of the items given below:

a) Brickwork in C.N. (1:6) with 10% extra bricks - unit 1 cum.

600 nos. country bricks.

0.38 m³ C.M. (1:6)

1.40 nos. Mason

0.7 nos. Man Mazdoor

1 nos. Woman Mazdoor

L.S. Sundries.

b) C.C. (1:5:10) using 40mm HBG metal unit 1 cum.

0.92 m³ 40mm size HBG metal

0.46 m³ Sand

0.09 m³ Cement

0 nos. Mason

1.8 nos. Man Mazdoor

1.4 nos. Woman Mazdoor

L.S. Sundries.

Lead Statement of materials:

Quantity of Cement required = $\frac{6}{10} \times 1.52 \times 15 = 13.68 \text{ m}^3$

Example 2:- Calculate the quantity of materials for the following items.

a) C.C. (1:4) for 10 m³ of work

b) C.P.I. (1:6) for 10 m³ of work

Hint: Cement will go to fill up the voids in sand. So total volume will be 4 instead of 10 m³

a) Quantity of Cement required = $\frac{1}{4} \times 10 = 2.5 \text{ m}^3 = 125 \text{ bags}$

Quantity of sand required = 10 m^3

b) Quantity of cement required = $10 \text{ m}^3 = 200 \text{ bags}$

Quantity of sand required = 10 m^3

Sl. No.	Material	Cost at Source Rs. Ps.	Per	Lead in Km	Conveyance Charges per Km
1	40mmHBG metal	210.00	m ₃	16	Rs.6=00/m ₃
2	Sand	16.00	m ₃	18	Rs.3=00/m ₃
3	Bricks country	780.00	1000Nos	at site	--
4	Cement	2600.0	10KN	at site	--

Labour charges:

i) Mason- Rs. 90 per day.

ii) Man Mazdoor - Rs. 70 per day

iii) Woman Mazdoor - Rs. 70 per day.

iv) Mixing Charges of C.M. Rs. 20.00 per m₃.

Lead Statement

Sl. No.	Material	Cost at Source Rs. Ps.	Per	Lead in Km	Conveyance Charges per Rs	Km Total conveyance Charge Rs	Total cost Rs. Ps
1	40mmHBG metal	210.00	m ₃	16	Rs.6/m ₃	96.00	306.00
2	Sand	16.00	m ₃	18	Rs.3/m ₃	54.00	70.00
3	Bricks country	780.00	1000Nos	at site	--	---	780.00
4	Cement	2600.0	10KN or 1tonne	at site	--	---	2600/t

a) B.M. CM(1:6) with country bricks -
1m₃ CM (1:6) - 0.38m₃

$$\text{Cost of Cement} = \left(\frac{1}{6} \times 0.38 \times 1.44 \right) \times 2600 = 237.12$$

$$\text{Cost of Sand} = \left(\frac{6}{6} \times 0.38 \right) \times 70 = 26.60$$

$$\text{Total Cost} \quad \text{Rs. } \underline{263.72}$$

S.No.	Description	Quantity	Unit	Rate	per	Amount Rs.
1	Country Bricks	600	Nos	780	1000	769.23
2	CM (1:6)	0.38	m ₃	263.72	0.38m ₃	263.72
3	Mason	1.4	Nos	90	day	126.00
4	Man mazdoors	2.1	Nos	70	day	147.00
5	Mixing Charges	0.38	m ₃	20	m ₃	7.60
6	Sundries	L.S				86.44

Total Rs 1400.00

Under

b) CC (1:5:10) using 40mm HBG metal -1m³

S.No.	Description	Quantity	Unit	Rate	per	Amount
1	40mm HBG metal	0.92	m ₃	306	m ₃	281.52
2	Sand	0.46	m ₃	70	m ₃	32.20
3	Cement	0.092	m ₃	2600	t	344.45
4	Mason	0.2	Nos	90	Nos	18.00
5	Man mazdoor	1.80	Nos	70	Nos	126.00
6	women Mazdoor	1.4	Nos	70	Nos	98.00
7	Mixing charges	1.0	m ₃	20	m ₃	20.00
8	Sun dries	L.S				4.83

Total Rs. 925.00 /m³

Preparation of Unit rates for finished items of works

I a) Cement Concrete in foundation (1:5:10)

S.No.	Description of Item	Quantity	Unit	Rate	Per	Amount
1.	40mm HBG Metal	0.92	Cum	547.75	Cum	503.93
2.	Sand	0.46	cum	284.80	Cum	131.00
3.	Cement	0.092	Cum	2700.00	MT	357.70
4.	Mason Ist Class	0.06	No	150.00	Nos	9.00
5.	Mason 2nd Class	0.14	No	131.00	Nos	18.34
6.	Man mazdoor	1.80	No	101.00	Nos	181.80
7.	Women Mazdoor	1.40	No	101.00	Nos	141.40
8.	Add Extra 15%on M.L					52.58
						1395.75
9	Add T.O.T. @4%					55.83
10	Sundries					0.42
Total Rs						1452.00

b). Cement Concrete in foundation (1:4:8)

S.No	Description of Item	Quantity	Unit	Rate	Per	Amount
1.	40mm HBG Metal	0.92	Cum	547.75	Cum	503.93
2.	Sand	0.46	Cum	284.80	Cum	131.00
3.	Cement	0.115	Cum	2700.00	MT	447.12
4.	Mason Ist Class	0.06	No	150.00	Nos	9.00
5.	Mason 2nd Class	0.14	No	131.00	Nos	18.34
6.	Man mazdoor	1.80	No	101.00	Nos	181.80
7.	Women Mazdoor	1.40	No	101.00	Nos	141.40
8.	Add Extra 15%on M.L					52.58
						1485.17
9	Add T.O.T. @4%					59.40
10	Sundries					0.43
Total Rs.						1545.00

Under

R.C.C.Works

V.R.C.C.(1:2:4) Nominal mix using 20mm Normal size hard broken granite metal approved quarry with necessary reinforcement including casting, curing cost & conveyance of all materials

a) P.C.C.(1:2:4)

S.No	Description of Item	Quantity	Unit	Rate	Per	Amount
1.	20mm HBG Metal	0.92	Cum	797.75	Cum	733.93
2.	Sand	0.46	cum	284.80	Cum	131.00
3.	Cement	0.23	Cum	2700.00	MT	894.24
4.	Mason Ist Class	0.2	No	180.00	Nos	30.00
5.	Man mazdoor	1.8	No	131.00	Nos	235.80.
6.	Women Mazdoor	1.4	No	101.00	Nos	141.40
7.	Vibrating charges	1.0	Cum	101.00	Nos	101.00
8.	Machiny mixing concrete	1.0	Cum	28.80	cum	28.80
9	Add Extra 15%on M.L					76.23
Total Rs.						2372.40

c) For steel reinforcement

S.No	Description of Item	Quantity	Unit	Rate	Per	Amount
1.	cost of steel	1.00	MT	27500	MT	27500.00
2.	Fabrication charges	1.00	MT	5.00	Kg	5000.00
3.	Add 15% on M.L.					750.00
						33250.00
4.	Add T.O.T. @4%					1330.00
5.	Sundries					0.00
Total Rs.						34580.00

Page-73

c) V.R.C.C (1:2:4) for bed blocks, column footings including form work Centring charges

S.No	Description of Item	Quantity	Unit	Rate	Per	Amount
1.	V.P.C.C (1:2:4)	1.00	Cum	2372.40	Cum	2372.40
2.	Centering Charges	1.00	Cum	430.00	Cum	430.00
3.	Steel @0.5% = 0.5/ 100=0.005m ₃ (0.005x7.85t/m ³ = 0.04t	0.04	MT	34580.00	MT	1383.20
						4185.60
4.	Add T.O.T. @4%					167.40
	Sundries					0.00
Total						4353.00

Under

d) V.R.C.C (1:2:4) for columns rectangular beams, pedestals including form work at centering charges.

S.No	Description of Item	Quantity	Unit	Rate	Per	Amount
1.	V.P.C.C. (1:2:4)	1.00	Cum	2372.40	Cum	2372.40
2.	Centering Charges	1.00	Cum	675.00	Cum	675.00
3.	Steel for columns, beams	0.117	MT	34580.00	MT	4072.00
	@ 1.5% = 1.5/ 100x7.85=0.117t					7119.40
4.	Add T.O.T. @4%					284.77
5.	Sundries					0.83
Total						7405.00

Pointing to R.R.Masonry in CM(1:4) mix using cost & conveyance of Cement, sand and all materials from approved sources to site and labour charges for point neatly etc

S.No	Description of Item	Quantity	Unit	Rate	Per	Amount
1.	Cost of CM(1:4) Cement =	0.09	Cum			
	$\left[\frac{1}{4} \times 1.44 \times 0.09 \right]$	0.032	T	2700.00	Mt	87.48
2.	Sand	0.09	Cum	284.80	Cum	25.63
3.	Mining Charges	1.0	Cum	32.50	Cum	32.50
4.	mason Ist Class	0.48	Nos.	150.00	Nos	72.00
5.	2nd Class	1.12	Nos	131.00	Nos	146.72
6.	Man mazdoor	0.50	Nos	101.00	Nos	55.00
7.	Women Mazdoor	1.10	Nos	101.00	Nos	111.10
8.	Add 15% on ML					57.72
9.	Add TOT @ 4%					588.15
10.	Sundries					23.53
						0.32
Total						612.00

Cement concrete flooring (1:2:4) using 12mm HBG machine crushed chips from approved quarry to site of work including curing cost and conveyance of all materials completed

S.No	Description of Item	Quantity	Unit	Rate	Per	Amount
1.	12mm HBG metal	0.92	Cum	680.25	cum	625.83
2.	crushed chips					
3.	Sand	0.46	cum	284.80	cum	131.00
4.	Cement	0.23	cum	2700	mt	894.24
	(0.23m ³ x1.44=0.33t (or)0.331	(or)0.331	MT			
5.	Mason Ist class	0.06	Nos	150.00	nos	9.00
6.	2nd Class	0.14	nos	131.00	nos	18.34
7.	Man mazdoor	1.80	nos	101.00	nos	181.80
8.	Women Mazdoor	1.40	nos	101.00	nos	141.40
9.	Add 15% Extra on ML					52.58
10	Add TOT @4%					2054.19
11.	Sundries					82.17
						0.64
Total						2137.00

Under

Module-III

Introduction:

A project is composed of jobs, activities, functions or tasks that are related one to the other in some manner, and all of these should be completed in order to complete the project.

A project is a temporary endeavor involving a connected sequence of activities and a range of resources, which is designed to achieve a specific and unique outcome and which operates within time, cost and quality constraints and which is often used to introduce change.

Characteristic of a project:

- A unique, one-time operational activity or effort
- Requires the completion of a large number of interrelated activities
- Established to achieve specific objective
- Resources, such as time and/or money, are limited
- Typically has its own management structure
- Need leadership

Examples:

1. A unique, one-time operational activity or effort
2. Requires the completion of a large number of interrelated activities
3. Established to achieve specific objective
4. Resources, such as time and/or money, are limited
5. Typically has its own management structure
6. Need leadership

Project management:

- The application of a collection of tools and techniques to direct the use of diverse resources towards the accomplishment of a unique, complex, one time task within time, cost and quality constraints.
- Its origins lie in World War II, when the military authorities used the techniques of operational research to plan the optimum use of resources.
- One of these techniques was the use of networks to represent a system of related activities

Under

Project Management Process:

- Project planning
- Project scheduling
- Project control
- Project team
 - made up of individuals from various areas and departments within a company
- Matrix organization
 - a team structure with members from functional areas, depending on skills required
- Project Manager
 - most important member of project team
- Scope statement
 - a document that provides an understanding, justification, and expected result of a project
- Statement of work
 - written description of objectives of a project
- Organizational Breakdown Structure
 - a chart that shows which organizational units are responsible for work items
- Responsibility Assignment Matrix
 - shows who is responsible for work in a project

Work breakdown structure:

- A method of breaking down a project into individual elements (components, subcomponents, activities and tasks) in a hierarchical structure which can be scheduled and cost
- It defines tasks that can be completed independently of other tasks, facilitating resource allocation, assignment of responsibilities and measurement and control of the project
- It is foundation of project planning
- It is developed before identification of dependencies and estimation of activity durations
- It can be used to identify the tasks in the CPM and PERT

Project Planning:

Under

- Resource Availability and/or Limits
 - Due date, late penalties, early completion incentives
 - Budget
- Activity Information
 - Identify all required activities
 - Estimate the resources required (time) to complete each activity
 - Immediate predecessor(s) to each activity needed to create interrelationships

Project Scheduling and Control Techniques:

Scheduling can be done by any of the following processes:

- Bar chart and Milestone Chart
- Critical Path Method (CPM)
- Program Evaluation and Review Technique (PERT)

Bar chart and Milestone Chart:

- Graph or bar chart with a bar for each project activity that shows passage of time
- Provides visual display of project schedule

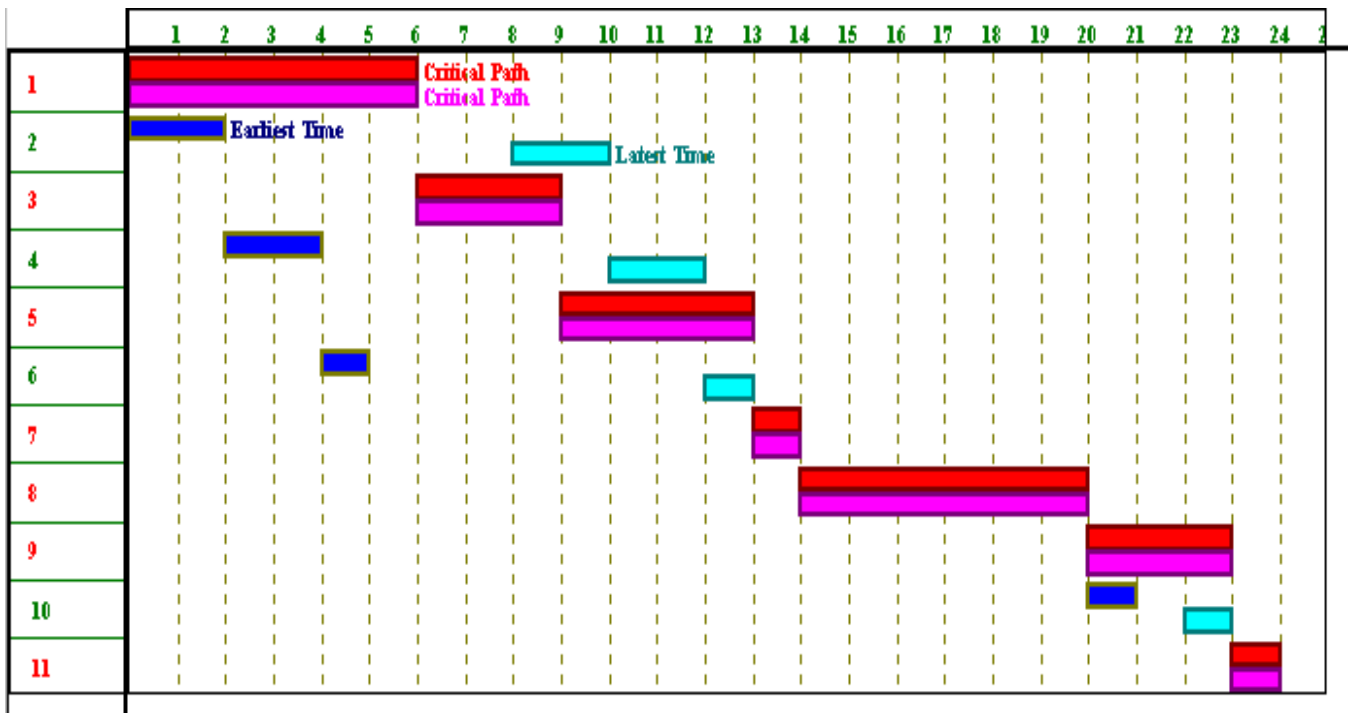

Weakness in charts Network-comparison:

1. On bar chart only major activities are shown. If too many activities are separately shown, it becomes clumsy. Due to this bar charts are not very useful for big projects.
2. A bar chart does not show the progress of work and hence it can not be used as control device. For proper control of the project, information of the progress made at a particular instant of time should be available.
3. It is not possible to show activity inter relationships of a project.
4. Bar charts are not at all useful in those projects where there are uncertainties in determination or estimation of time required for the completion of various activities.

PERT and CPM:

Introduction:

One of the most challenging jobs that any manager can take on is the management of a large-scale project that requires coordinating numerous activities throughout the organization. A myriad of details must be considered in planning how to coordinate all these activities, in developing a realistic schedule, and then in monitoring the progress of the project.

Fortunately, two closely related operations research techniques, **PERT** (program evaluation and review technique) and **CPM** (critical path method), are available to assist the project manager in carrying out these responsibilities. These techniques make heavy use of *networks* to help plan and display the coordination of all the activities.

PERT and CPM have been used for a variety of projects, including the following types.

1. Construction of a new plant
2. Research and development of a new product
3. NASA space exploration projects
4. Movie productions
5. Building a ship
6. Government-sponsored projects for developing a new weapons system

Under

7. Relocation of a major facility
8. Maintenance of a nuclear reactor
9. Installation of a management information system
10. Conducting an advertising campaign

Project Networks:

A network used to represent a project is called a project network. A project network consists of a number of nodes (typically shown as small circles or rectangles) and a number of arcs (shown as arrows) that connect two different nodes.

Network analysis is the general name given to certain specific techniques which can be used for the planning, management and control of projects

Use of nodes and arrows:

Arrows:

- An arrow leads from tail to head directionally
- Indicate ACTIVITY, a time consuming effort that is required to perform a part of the work.

Nodes:

- A node is represented by a circle
- Indicate EVENT, a point in time where one or more activities start and/or finish.

Activity

- A task or a certain amount of work required in the project
- Requires time to complete
- Represented by an arrow

Dummy Activity

- Indicates only precedence relationships
- Does not require any time of effort

Event

- Signals the beginning or ending of an activity
- Designates a point in time
- Represented by a circle (node)

Under

Network

- Shows the sequential relationships among activities using nodes and arrows

Three types of information are needed to describe a project:

- Activity information: Break down the project into its individual activities (at the desired level of detail).
- Precedence relationships: Identify the immediate predecessor(s) for each activity.
- Time information: Estimate the duration of each activity.

The project network should convey all this information. Two alternative types of project networks are available for doing this.

- One type is the activity-on-arc (AOA) project network, where each activity is represented by an arc. A node is used to separate an activity (an outgoing arc) from each of its immediate predecessors (an incoming arc). The sequencing of the arcs thereby shows the precedence relationships between the activities.
- The second type is the activity-on-node (AON) project network, where each activity is represented by a node. Then the arcs are used just to show the precedence relationships that exist between the activities. In particular, the node for each activity with immediate predecessors has an arc coming in from each of these predecessors.

The original versions of PERT and CPM used AOA project networks, so this was the conventional type for some years. However, AON project networks have some important advantages over AOA project networks for conveying the same information.

- AON project networks are considerably easier to construct than AOA project networks.

Under

- AON project networks are easier to understand than AOA project networks for inexperienced users, including many managers.
- AON project networks are easier to revise than AOA project networks when there are changes in the project.

Example:

AOA Project Network for House:

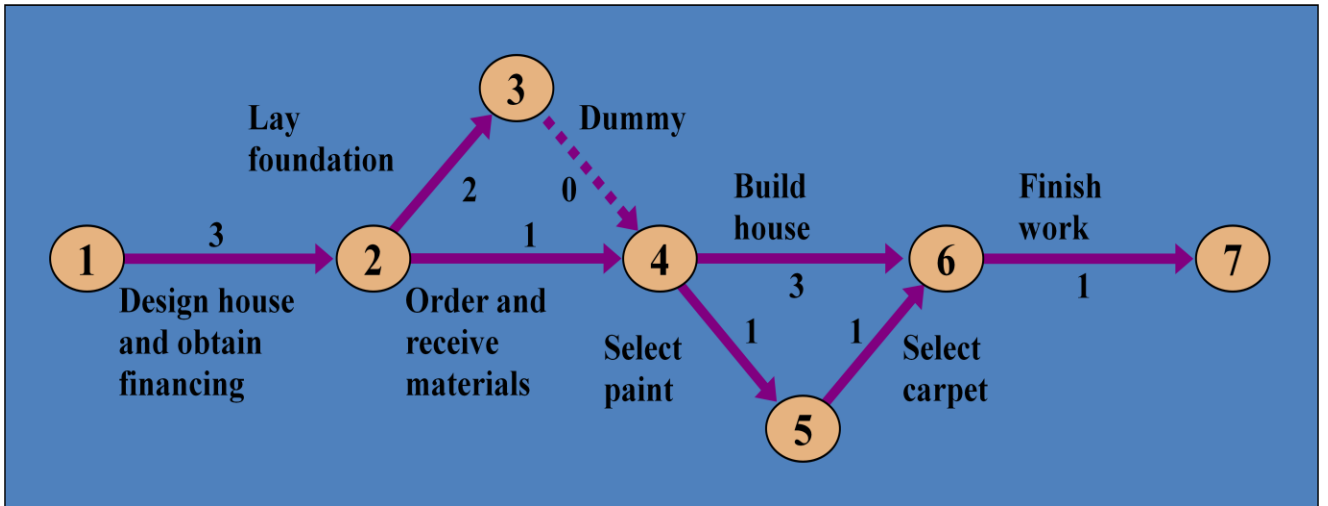

AON Project Network for House:

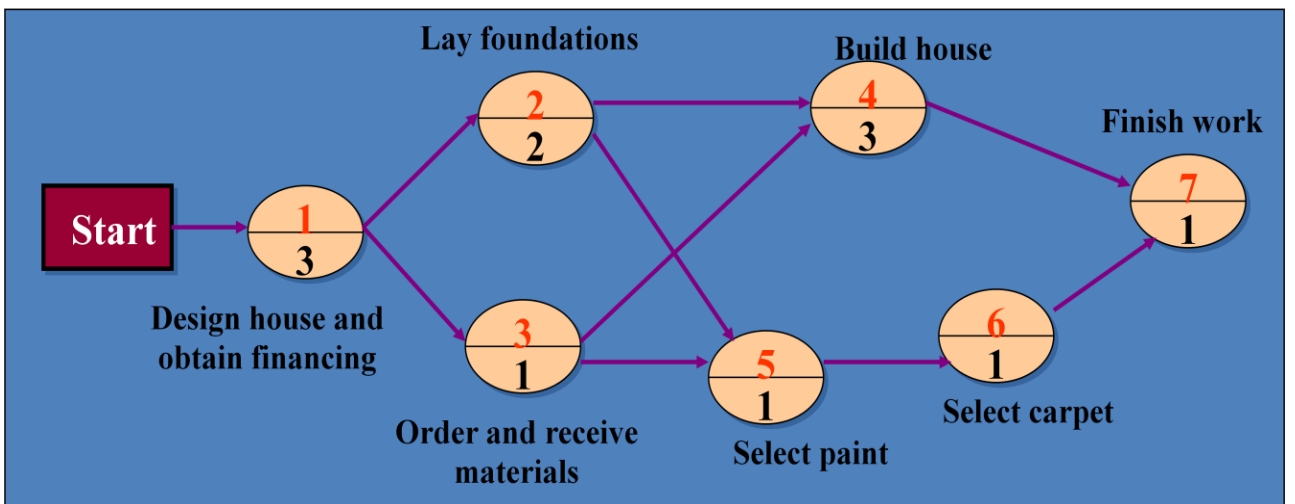

Situations in network diagram:

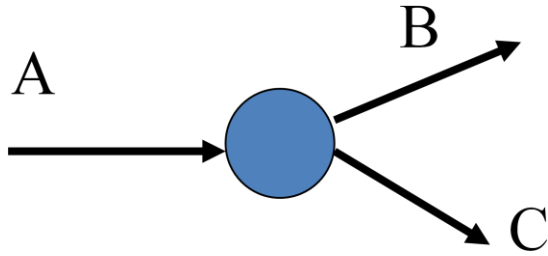

(**A** must finish before either **B** or **C** can start)

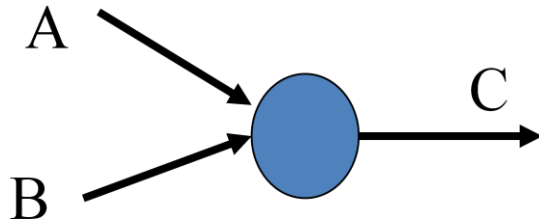

(Both **A** and **B** must finish before **C** can start)

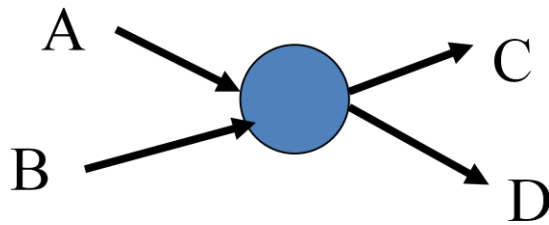

(Both **A** and **C** must finish before either of **B** or **D** can start)

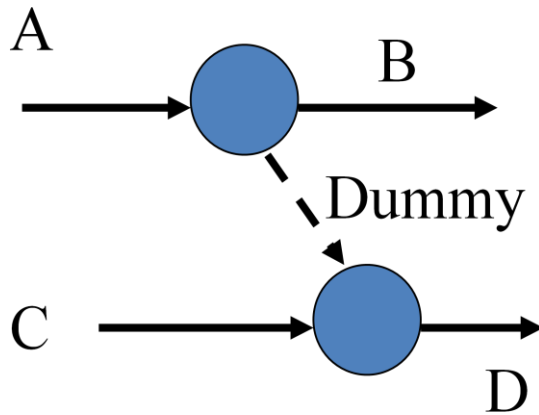

(A must finish before B can start both A and C must finish before D can start)

Concurrent Activities:

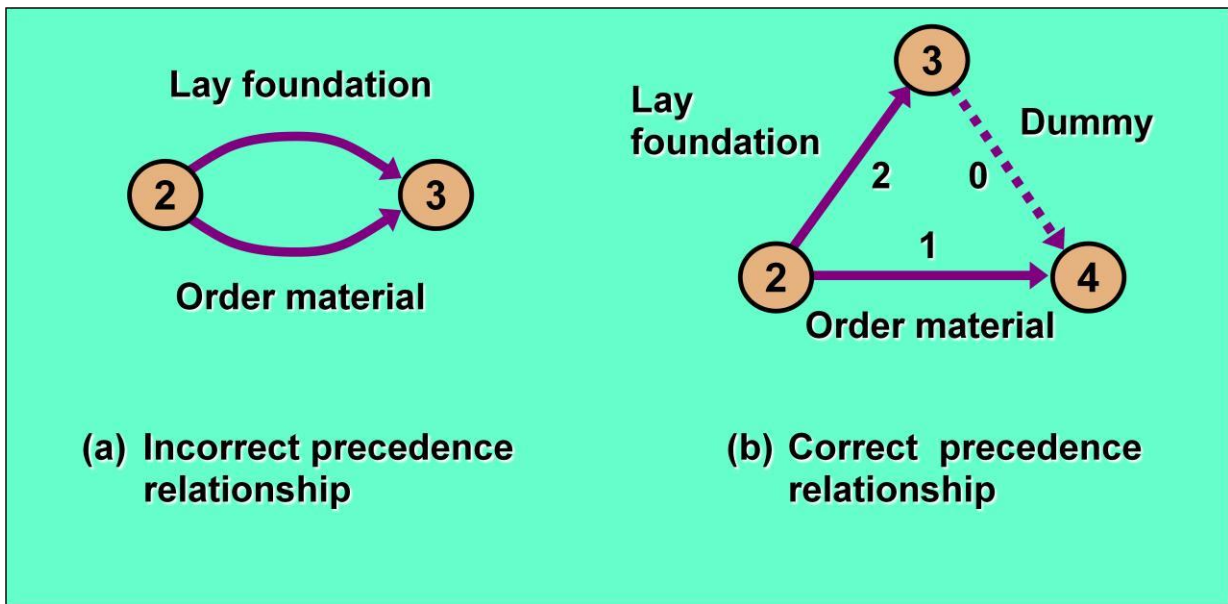

Network example:

Illustration of network analysis of a minor redesign of a product and its associated packaging.

The key question is: How long will it take to complete this project?

Activity number		Completion time (weeks)
1	Redesign product	6
2	Redesign packaging	2
3	Order and receive components for redesigned product	3
4	Order and receive material for redesigned packaging	2
5	Assemble products	4
6	Make up packaging	1
7	Package redesigned product	1
8	Test market redesigned product	6
9	Revise redesigned product	3
10	Revise redesigned packaging	1
11	Present results to the Board	1

For clarity, this list is kept to a minimum by specifying only immediate relationships, that is relationships involving activities that "occur near to each other in time".

Activity number		Activity number
1	must be finished before	3
2		4
3		5
4		6
5, 6		7
7		8
8		9
8		10
9, 10		11

Questions to prepare activity network:

- Is this a Start Activity?
- Is this a Finish Activity?
- What Activity Precedes this?

Under

- What Activity Follows this?
- What Activity is Concurrent with this?

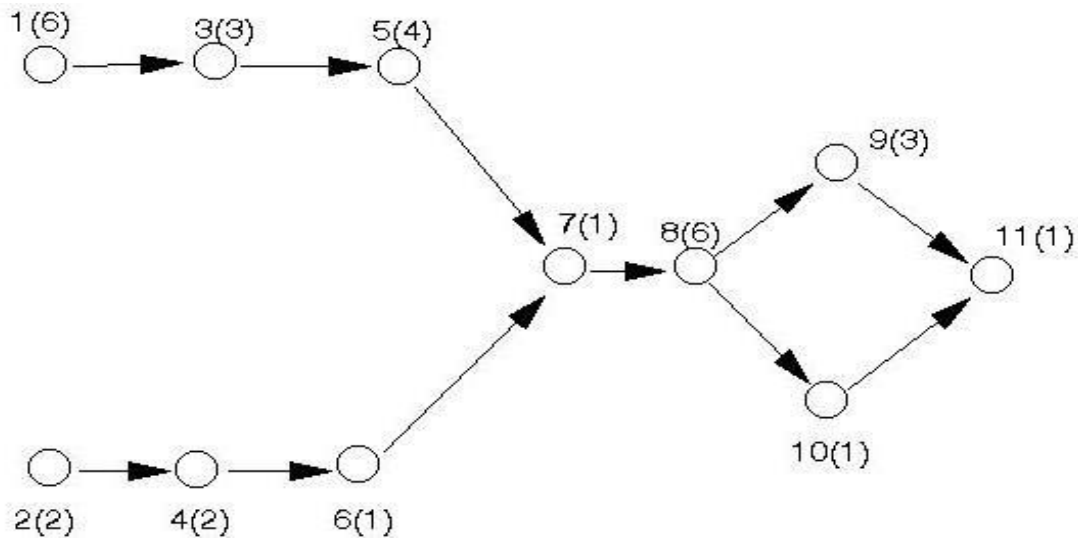

CPM calculation:

- **Path**
 - A connected sequence of activities leading from the starting event to the ending event
- **Critical Path**
 - The longest path (time); determines the project duration
- **Critical Activities**
 - All of the activities that make up the critical path

Forward Pass:

- **Earliest Start Time (ES)**
 - earliest time an activity can start
 - ES = maximum EF of immediate predecessors
- **Earliest finish time (EF)**

- earliest time an activity can finish
- earliest start time plus activity time
- $EF = ES + t$

Backward Pass:

♦ Latest Start Time (LS)

Latest time an activity can start without delaying critical path time

$LS = LF - t$

♦ Latest finish time (LF)

Latest time an activity can be completed without delaying critical path time

$LS = \text{minimum LS of immediate predecessors}$

Arc with ES & EF time:

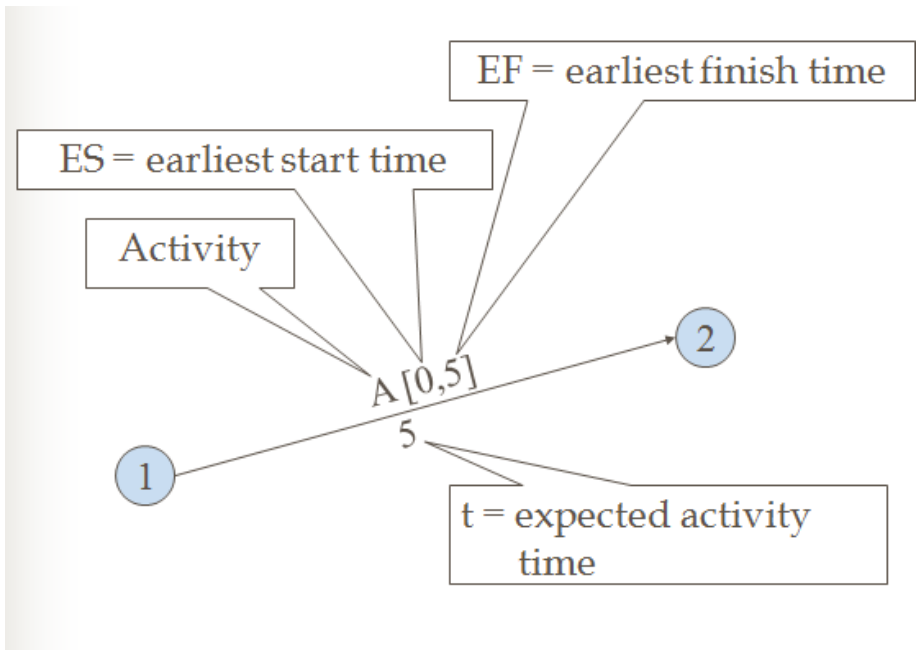

Network with ES & EF time:

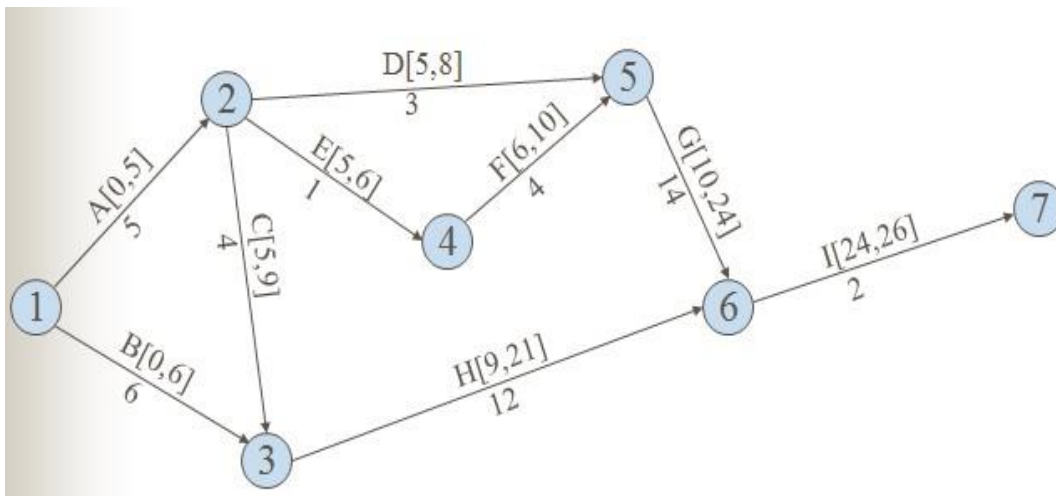

Earliest start time rule:

The earliest start time for an activity leaving a particular node is equal to the largest of the earliest finish times for all activities entering the node.

Activity, duration, ES, EF, LS, LF:

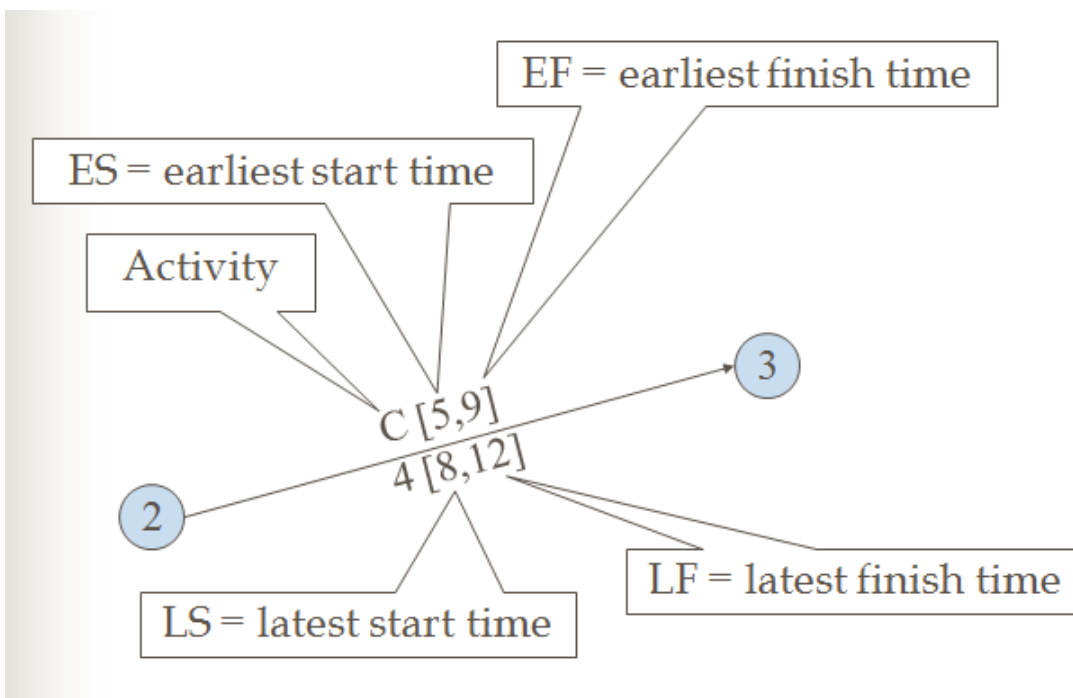

Latest start & latest finish time:

- To find the critical path we need a backward pass calculation.

Under

- Starting at the completion point (node 7) and using a latest
- finish time (LF) of 26 for activity I, we trace back through the
- network computing a latest start (LS) and latest finish time
- for each activity
- The expression $LS = LF - t$ can be used to calculate latest start
- time for each activity. For example, for activity I, $LF = 26$ and t
- $= 2$, thus the latest start time for activity I is

$$LS = 26 - 2 = 24$$

Network with LS & LF time:

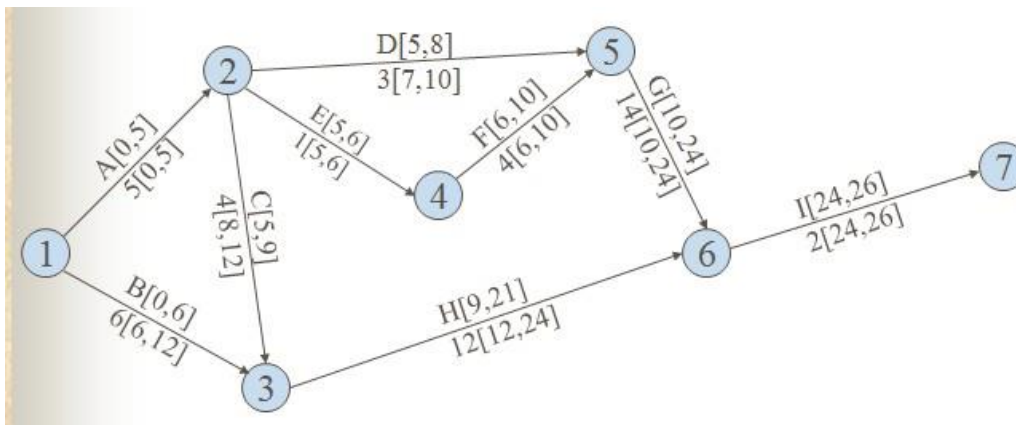

Latest finish time rule:

The latest finish time for an activity entering a particular node is equal to the smallest of the latest start times for all activities leaving the node.

Slack or Free Time or Float:

Slack is the length of time an activity can be delayed without affecting the completion date for the entire project.

For example, slack for C = 3 weeks, i.e Activity C can be delayed up to 3 weeks

Under

(start anywhere between weeks 5 and 8).

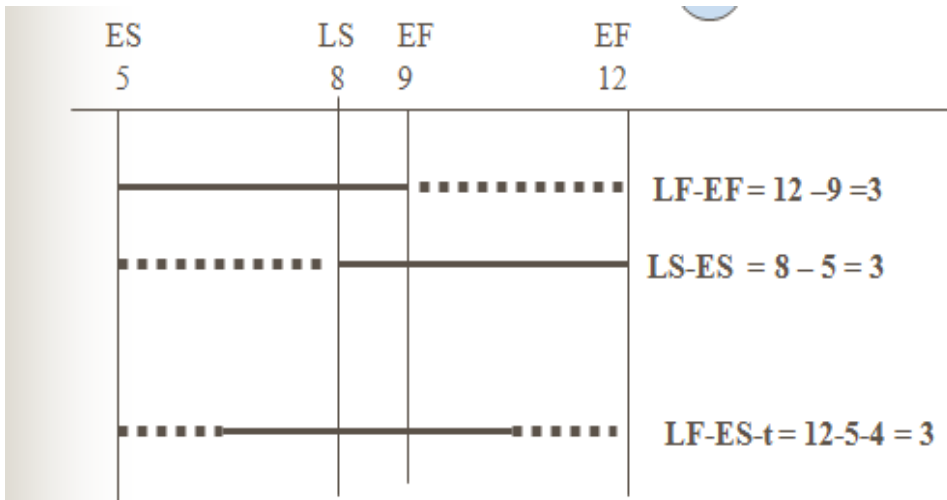
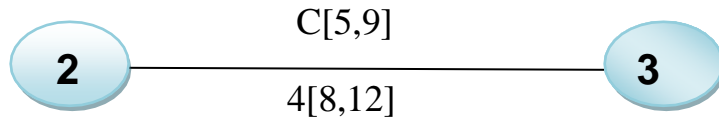

Importance of Float (Slack) and Critical Path:

1. Slack or Float shows how much allowance each activity has, i.e how long it can be delayed without affecting completion date of project
2. Critical path is a sequence of activities from start to finish with zero slack. Critical activities are activities on the critical path.
3. Critical path identifies the minimum time to complete project
4. If any activity on the critical path is shortened or extended, project time will be shortened or extended accordingly
5. So, a lot of effort should be put in trying to control activities along this path, so that project can meet due date. If any activity is lengthened, be aware that project will not meet deadline and some action needs to be taken.
6. If can spend resources to speed up some activity, do so only for critical activities.

7. Don't waste resources on non-critical activity, it will not shorten the project time.
8. If resources can be saved by lengthening some activities, do so for non-critical activities, up to limit of float.
9. Total Float belongs to the path

PERT:

- PERT is based on the assumption that an activity's duration follows a probability distribution instead of being a single value
- Three time estimates are required to compute the parameters of an activity's duration distribution:
 - pessimistic time (t_p) - the time the activity would take if things did not go well
 - most likely time (t_m) - the consensus best estimate of the activity's duration
 - optimistic time (t_o) - the time the activity would take if things did go well

Mean (expected time): $t_e = \frac{t_p + 4 t_m + t_o}{6}$

Variance: $V_t = \sigma^2 = \left(\frac{t_p - t_o}{6} \right)^2$

PERT analysis:

- Draw the network.
- Analyze the paths through the network and find the critical path.
- The length of the critical path is the mean of the project duration probability distribution which is assumed to be normal
- The standard deviation of the project duration probability distribution is computed by adding the variances of the critical activities (all of the activities that make up the critical path) and taking the square root of that sum
- Probability computations can now be made using the normal distribution table.

Probability computation:

- So far, times can be estimated with relative certainty, confidence
- For many situations this is not possible, e.g Research, development, new products and projects etc.
- Use 3 time estimates

m = most likely time estimate, mode.

a = optimistic time estimate,

b = pessimistic time estimate, and

Expected Value (TE) = $(a + 4m + b) / 6$

Variance (V) = $((b - a) / 6)^2$

Std Deviation (δ) = $\text{SQRT}(V)$

Normal Distribution of Project Time:

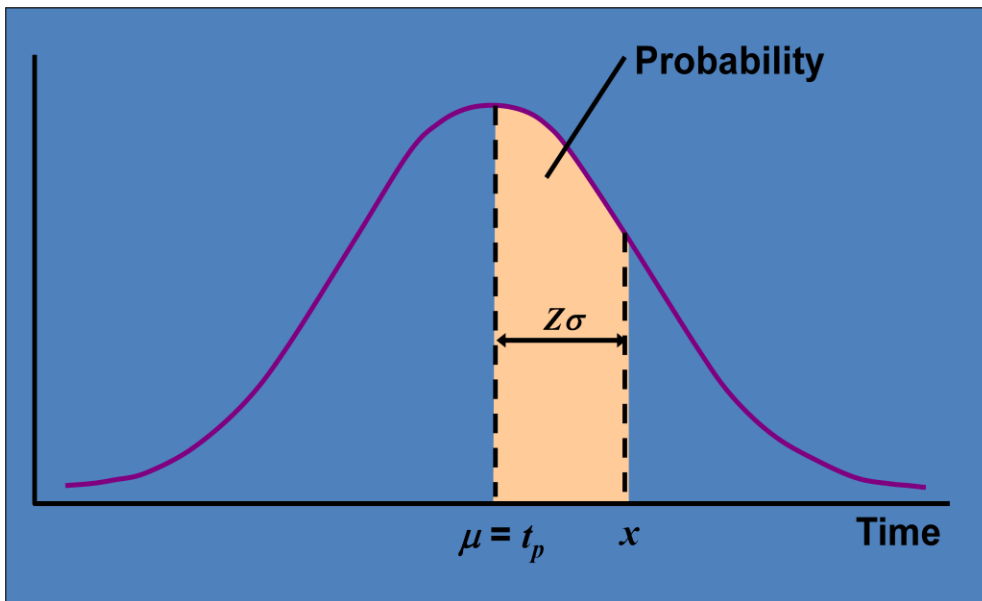

EXAMPLE:

Precedences and project activity times:

Activity	Immediate Predecessor	Optimistic Time	Most Likely Time	Pessimistic Time	EXP TE	Var V	S.Dev σ
a	-	10	22	22	20	4	2
b	-	20	20	20	20	0	0
c	-	4	10	16	10	4	2
d	a	2	14	32	15	25	5 ^t
e	b,c	8	8	20	10	4	2
f	b,c	8	14	20	14	4	2
g	b,c	4	4	4	4	0	0
h	c	2	12	16	11	5.4	2.32
l	g,h	6	16	38	18	28.4	5.33
j	d,e	2	8	14	8	4	2

Under

The complete Network:

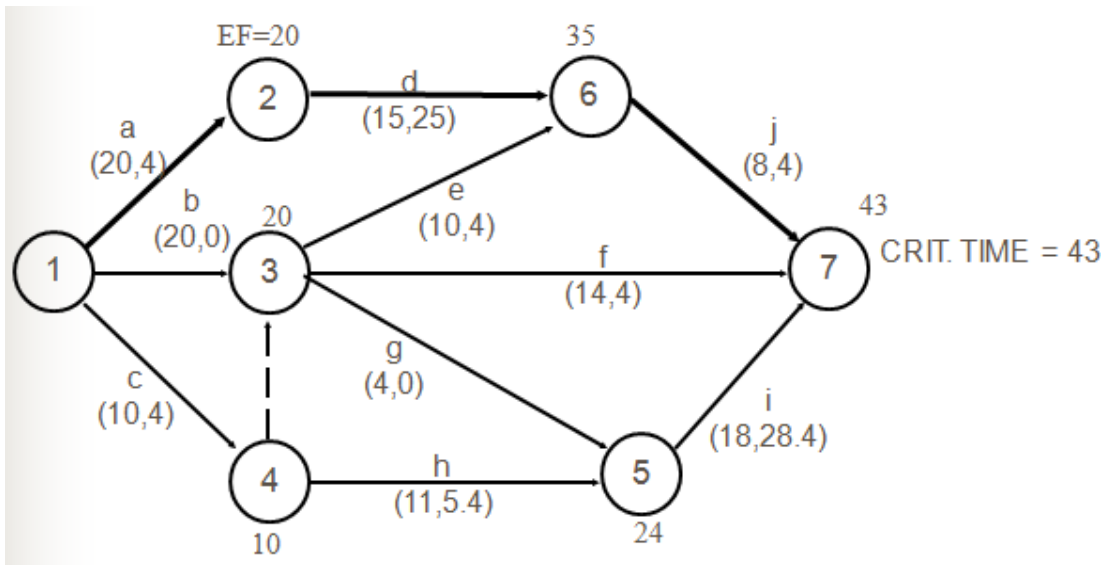
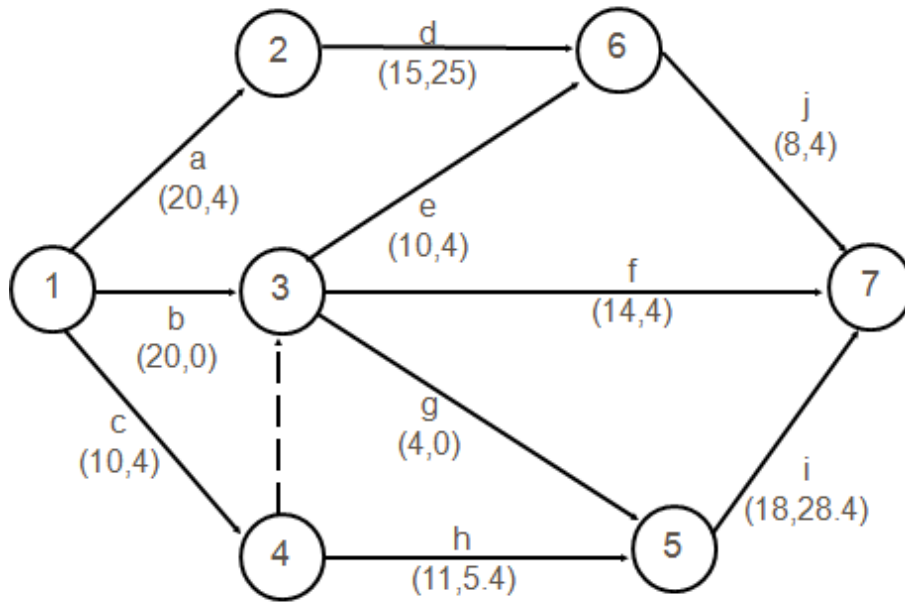

Under

Critical Path Analysis (PERT):

Activity	LS	ES	Slacks	Critical ?
a	0	0	0	Yes
b	1	0	1	
c	4	0	4	
d	20	20	0	Yes
e	25	20	5	
f	29	20	9	
g	21	20	1	
h	14	10	4	
i	25	24	1	
j	35	35	0	Yes

Assume, PM promised to complete the project in the fifty days.

What are the chances of meeting that deadline?

Calculate Z, where

$$Z = (D-S) / \sqrt{V}$$

Example,

$$D = 50; \quad S(\text{Scheduled date}) = 20+15+8 = 43; \quad V = (4+25+4) \\ = 33$$

$$Z = (50 - 43) / 5.745 \\ = 1.22 \text{ standard deviations.}$$

Under

The probability value of $Z = 1.22$, is 0.888

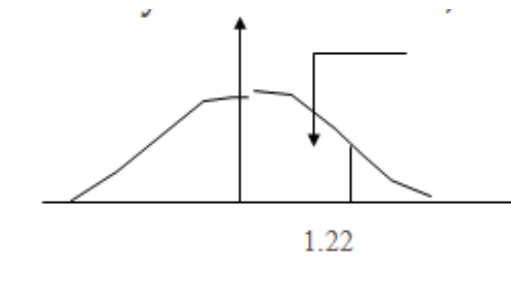

What deadline are you 95% sure of meeting

Z value associated with 0.95 is 1.645

$$D = S + 5.745 (1.645)$$

$$= 43 + 9.45$$

$$= 52.45 \text{ days}$$

Thus, there is a 95 percent chance of finishing the project by 52.45 days.

Comparison Between CPM and PERT:

	CPM	PERT
1	Uses network, calculate float or slack, identify critical path and activities, guides to monitor and controlling project	Same as CPM
2	Uses one value of activity time	Requires 3 estimates of activity time Calculates mean and variance of time
3	Used where times can be estimated with confidence, familiar activities	Used where times cannot be estimated with confidence. Unfamiliar or new activities
4	Minimizing cost is more important	Meeting time target or estimating percent completion is more important

Under

5	Example: construction projects, building one off machines, ships, etc	Example: Involving new activities or products, research and development etc
---	---	---

BENEFITS OF CPM / PERT NETWORK:

Consistent framework for planning, scheduling, monitoring, and controlling project.

- Shows interdependence of all tasks, work packages, and work units.
- Helps proper communications between departments and functions.
- Determines expected project completion date.
- Identifies so-called critical activities, which can delay the project completion time.
- Identified activities with slacks that can be delayed for specified periods without penalty, or from which resources may be temporarily borrowed
- Determines the dates on which tasks may be started or must be started if the project is to stay in schedule.
- Shows which tasks must be coordinated to avoid resource or timing conflicts.
- Shows which tasks may run in parallel to meet project completion date